

DIVISION OF THE HUMANITIES AND SOCIAL SCIENCES

CALIFORNIA INSTITUTE OF TECHNOLOGY

PASADENA, CALIFORNIA 91125

DIVERGENCE, CLOSED CYCLES AND CONVERGENCE IN SCARF ENVIRONMENTS: EXPERIMENTS IN THE DYNAMICS OF GENERAL EQUILIBRIUM SYSTEMS

Masayoshi Hirota
Tokyo University of Science

Ming Hsu
California Institute of Technology

Charles R. Plott
California Institute of Technology

Brian W. Rogers
California Institute of Technology

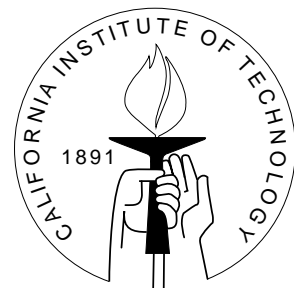

SOCIAL SCIENCE WORKING PAPER 1239

October 2005

Divergence, Closed Cycles and Convergence in Scarf Environments: Experiments in the Dynamics of General Equilibrium Systems

Masayoshi Hirota Ming Hsu Charles R. Plott Brian W. Rogers

ABSTRACT

Previous experimental work has demonstrated the power of the classical theory of economic dynamics. In particular, the models have proved to be accurate in predicting the principle directions of movement and orbit-like behavior in general equilibrium systems. Questions left open and addressed in this study are (i) do the markets necessarily converge to a unique interior equilibrium or can markets exhibit the “explosive property” of instability and (ii) among the several variations of the classical model, which, if any, is most accurate in predicting what is actually observed in experiments?

Markets were created and studied in the extreme environments identified by Scarf and Hirota. Such environments allow us to study features of market adjustments that are obscured by the complexity of naturally occurring markets. Two fundamental results are reported. First, the instability phenomenon of “expanding orbits” predicted by theory does actually exist in the markets and exists in much the form that theory suggests. That is, prices spiral outwardly around the equilibrium prices and do so in directions predicted by theory. This type of disequilibrium behavior is observed for the first time in actual market behavior. Thus, the principles governing market adjustment are not among those that guarantee convergence to a unique interior equilibrium. Second, the best dynamic model from among those studied is of the form

$$\begin{pmatrix} \dot{P}_1/P_1 \\ \dot{P}_2/P_2 \end{pmatrix} = \begin{bmatrix} a_{11} & 0 \\ 0 & a_{22} \end{bmatrix} \begin{pmatrix} E_1(P_1, P_2) \\ E_2(P_1, P_2) \end{pmatrix}$$

where the diagonal elements are positive and the $E_i(P)$ are excess demands.

JEL classification numbers: D50, C92, E3

Key words: general equilibrium, stability, experiments

Divergence, Closed Cycles and Convergence in Scarf Environments: Experiments in the Dynamics of General Equilibrium Systems

Masayoshi Hirota, Tokyo University of Science
Ming Hsu, California Institute of Technology
Charles R. Plott, California Institute of Technology
Brian W. Rogers, California Institute of Technology

1. Introduction*

While modern experiments have made remarkable progress toward an understanding of the dynamics of price and allocation changes in multiple market systems, fundamental questions remain. Experimentalists have discovered that classical models, which are based on an assumption of tatonnement, have remarkable explanatory power even when applied to the non-tatonnement, continuous, double auction markets. Such discoveries lead naturally to investigations of the most fundamental properties of the underlying models. The experiments reported here focus on environments in which the classical models make rather "extreme" predictions and ask if the data reflect any of the substantive properties predicted. In particular, the question posed is whether or not general equilibrium systems can exhibit the property of instability, as opposed to inevitable convergence to any equilibrium whether stable or unstable.

Existing experiments in one price dimension have demonstrated that single markets can in fact be unstable¹ but, on the other hand, experiments have also demonstrated underlying stabilizing forces.² Experiments in a general equilibrium framework have demonstrated that the classical model can do a remarkable job of predicting the directions of price movement in multiple market systems. In particular, "orbit like" behavior can be observed when the model predicts orbits in two-dimensional price space.³ Furthermore, classical models of dynamics even predict the direction of such "orbit like" behavior.

* The financial support of the National Science Foundation and the Caltech Laboratory for Experimental Economics and Political Science is gratefully acknowledged. We thank Anjan Mukherji, Ken-Inchi Shimomura, Bill Zame, and Peter Bossaerts for their many helpful suggestions.

¹ The phenomenon of market instability is first observed in Plott and George (1992) for the case of a Marshallian externality and replicated by Plott and Smith (1999). Instability in the case of income effects is first observed in Plott (2000).

² Carlson (1967) first notes that expectations based on past prices in a cobweb model will stabilize the price dynamics. This process is observed and reported in Johnson and Plott (1989).

³ Anderson, Plott, Shimomura, and Granat (2004).

However, key aspects of the dynamics remain unknown. Existing data cannot be used to determine if the markets are actually traveling in a closed orbit as predicted by theory, as opposed to moving in slowly decreasing orbits that converge to the equilibrium or whether they are diverging. Indeed, evidence exists that suggests the principles will lead to ultimate convergence.⁴ To summarize, in a broad sense the data help characterize the basic laws of dynamic market adjustment but fundamental and important details remain open.⁵ In this paper, we initiate a process of isolating those laws.

The paper consists of eight sections and four appendices. The next section, Section 2, provides some background on the structure of classical dynamic models. The emphasis here is on the basic principles as opposed to the consequences of those principles. Interestingly enough, since experimental methods are to be employed, one is free to consider broad classes of principles even though important implications of those principles might be unknown. Thus, while the section is brief it nevertheless attempts to partition deep issues of basic theory and isolate classes of models, each of which can be pursued in greater depth should experiments at any stage suggest the productivity of such investigation. This second section suggests the logic of the investigation.

Section 3 contains the detailed description of the experimental parameters, preferences, endowments, and market organization. An understanding of these facts is necessary for any understanding of what the patterns of data imply about theory. Section 4 contains an application of the classical model to the experimental environment. The competitive equilibrium is computed and the predicted price dynamics of the classical model are illustrated. Section 5 contains the experimental procedures and the experimental design. The number of experiments and the conditions under which each was conducted are outlined in the section. Section 6 describes a typical experiment. The figures here help carry an intuition about what was observed and why the models perform as they do.

Section 7 contains the results. The process of model comparison is described and the sequence of conclusions that follow from the analysis are outlined. The major

⁴ Asparouhova, Bossaerts, and Plott (2003).

⁵ A recent manuscript by Gjerstad (2004) explores a significantly different set of laws from those explored here.

conclusions are that the data move away from the competitive equilibrium, as predicted by the classical model, not toward it. The model that best captures the dynamics of the price movement and the basic law that governs the dynamics of multiple market adjustment contains a striking pattern of zeros and is of the form:

$$\begin{pmatrix} \dot{P}_1 \\ \dot{P}_2 \end{pmatrix} = \begin{bmatrix} P_1 & 0 \\ 0 & P_2 \end{bmatrix} \begin{bmatrix} a_{11} & 0 \\ 0 & a_{22} \end{bmatrix} \begin{pmatrix} E_1(P) \\ E_2(P) \end{pmatrix}, \text{ i.e., } \begin{pmatrix} \dot{P}_1/P_1 \\ \dot{P}_2/P_2 \end{pmatrix} = \begin{bmatrix} a_{11} & 0 \\ 0 & a_{22} \end{bmatrix} \begin{pmatrix} E_1(P_1, P_2) \\ E_2(P_1, P_2) \end{pmatrix}$$

Finally, Section 8 summarizes our conclusions.

2. Background Concepts: Models of Dynamics and Classical Principles of Dynamic Adjustment

Excellent reviews of classical dynamics are developed by McKenzie (2002) and by Mukherji (2002, 2003). While much more general models can be imagined our study begins with theories that are special cases of the following form:

$$(1) \dot{P} = A(P)E(P)$$

where P is the price vector, and $A(P)$ is a matrix of coefficients that may depend on prices P , and $E(P)$ is a vector of excess demands as a function of prices. It should be understood that the theory can be very general but the experiments explored here are all in two dimensional prices (three commodities and thus two price ratios) so much of the notation in the sequel will be in two price dimensions. From time to time, both the limited notation and full matrix notation will be used without confusion.

The primary feature of this model is that the rates of price changes depend upon P through the matrix $A(P)$ in addition to the functional relationship dictated by the fact that prices are in the excess demand functions. We are unaware of any attempt to study the model at this level of generality so we focus on classes of special cases, although the literature is rich with discussion about the conditions under which less information is required for convergence. See Mukherji (1995) for a summary of recent literature, and for a treatment of stability in three commodity (two prices) models see Mukherji (2004). Letting the elements of $A(P)$ be non-constant with respect to P , two special cases can be found in the literature.

The first is based on the principle that the rate of adjustment of a given market is a linear function of excess demands in all markets scaled by the price that prevails in that market. The function $A(P)$ becomes decomposed into a matrix that contains the prices and a matrix of constants which pre-multiplies the excess demand functions.

$$(2) \quad \begin{pmatrix} \dot{P}_1 \\ \dot{P}_2 \end{pmatrix} = \begin{bmatrix} P_1 & 0 \\ 0 & P_2 \end{bmatrix} \begin{bmatrix} a_{11} & a_{12} \\ a_{21} & a_{22} \end{bmatrix} \begin{pmatrix} E_1(P) \\ E_2(P) \end{pmatrix}$$

An alternative way of expressing this particular theory is that the percentage change in price depends on a constant $A(P)$ matrix, that is, the elements of the A matrix are all constants, and Excess demands. The formulas written this way are:

$$(3) \quad \frac{\dot{P}_i}{P_i} = a_{i1}E_1(P) + a_{i2}E_2(P), \quad i = 1, 2 \text{ for the two-dimensional case.}$$

Of course, this model can be further refined by hypotheses focused on the numbers a_{ij} . In particular, as will be demonstrated by our major result, the off diagonal elements might be zero and the diagonal elements positive.

The second model is based on the Newton method of solving equations. That is, the price system acts as if for small changes it is approximating the numerical process of Newton. Thus, the inverse of the Jacobian matrix is the integral part of the adjustment equations.

$$(4) \quad \dot{P} = -J(P)^{-1}E(P)$$

Where $A(P) = -J(P)^{-1}$ is the inverse of the Jacobian matrix derived from the vector of excess demands $E(P)$. The central structure of models of this form are developed by Smale (1976), Saari (1985), and Mukherji (1995), who identify the possible need of (possibly all) higher order derivatives in the adjustment process to assure convergence. Experimental evidence for this model is presented in Asparouhova, Bossaerts, and Plott (2003).

A second class of models sets $A(P)$ to be a constant matrix, independent of P . The most general of such formulations in which other special cases are nested is:

$$(5) \quad \begin{pmatrix} \dot{P}_1 \\ \dot{P}_2 \end{pmatrix} = \begin{bmatrix} a_{11} & a_{12} \\ a_{21} & a_{22} \end{bmatrix} \begin{pmatrix} E_1(P) \\ E_2(P) \end{pmatrix}$$

Notice that in this model the rate of adjustment in a single market given fixed prices in all markets depends on the state of disequilibrium in the other markets. That is, while demand might be greater than supply in one market the fact that another market is in disequilibrium might cause prices to go down. Walras tended to reject this as a possibility and postulated a “fundamental principle” that the direction of price change in a given market depended only on the sign of its own excess demand.

Following the intuition of Walras two special cases evolved in classical theory and are special cases of the equation above. The two special cases involve diagonal matrices. Both of these express the importance of, if not the possibility of, partial equilibrium analysis in the sense that the law of supply and demand operates in markets independently. According to the principles embedded in these models the adjustment in a market depends only on its own excess demand and not on whether other markets are in equilibrium or disequilibrium. Thus, adjustment in a single market can be studied independent of the state of equilibrium of other markets. While prices in other markets might influence a given market through the excess demands, the state of disequilibrium in the other markets does not. Of course, this hypothesis forms the foundation of partial equilibrium analysis.

The only difference in the theory, which appears to be due to Samuelson’s generalization of Hicks, is that on the more general version the speed of adjustment need not be equal to excess demand and instead can be scaled from excess demand.

$$(6) \quad \begin{pmatrix} \dot{P}_1 \\ \dot{P}_2 \end{pmatrix} = \begin{bmatrix} a_{11} & 0 \\ 0 & a_{22} \end{bmatrix} \begin{pmatrix} E_1(P) \\ E_2(P) \end{pmatrix}$$

Of course, the special case that attracts attention because of its simplicity is:

$$(7) \quad \begin{pmatrix} \dot{P}_1 \\ \dot{P}_2 \end{pmatrix} = \begin{bmatrix} 1 & 0 \\ 0 & 1 \end{bmatrix} \begin{pmatrix} E_1(P) \\ E_2(P) \end{pmatrix}.$$

Figure 1: Preference Parameters for the Clockwise Case

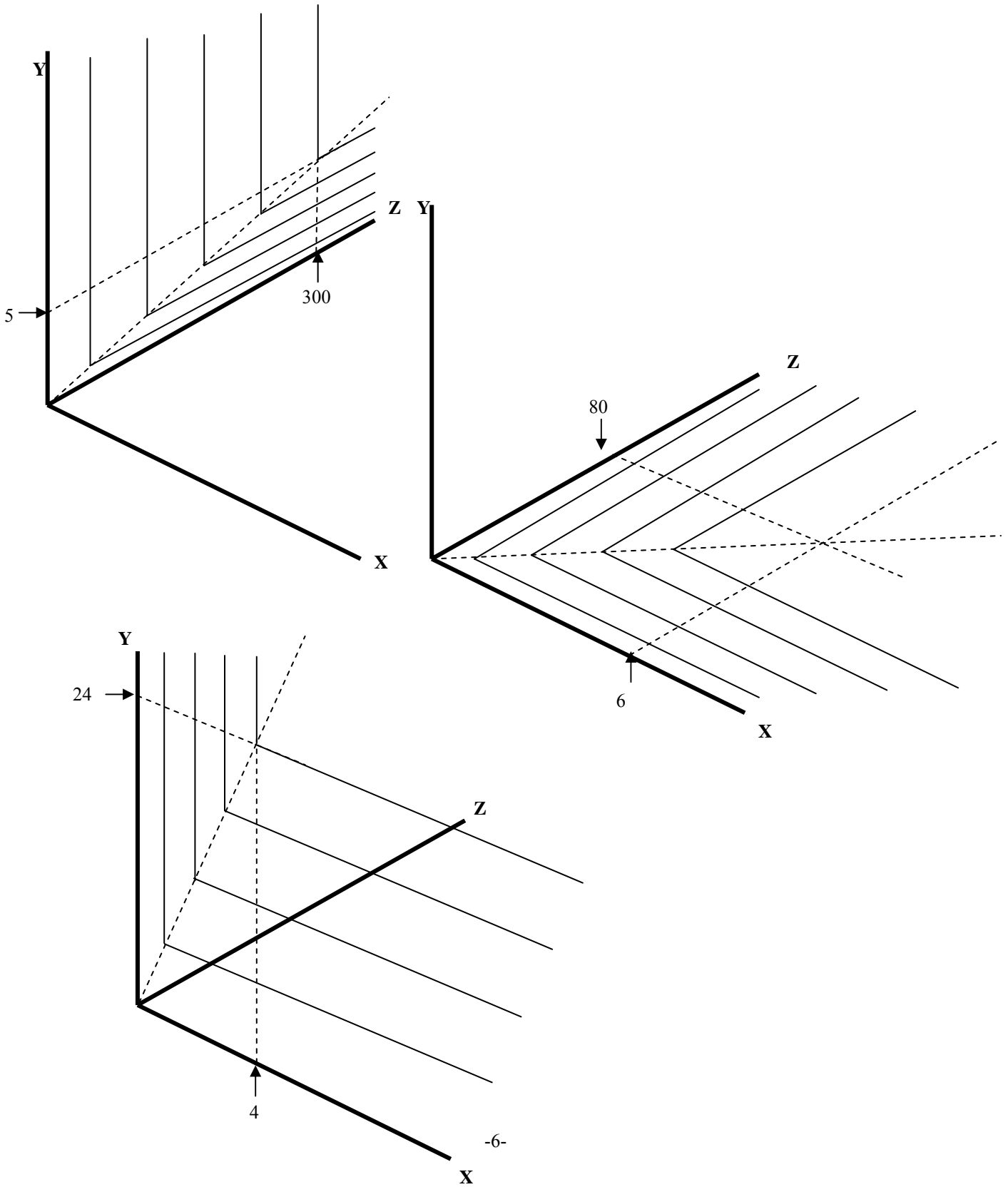

3. Experimental Environment

A. Preferences and Endowments

The preferences employed in our experiments are similar to those studied by Scarf (1960) and Hirota (1981) and studied experimentally by Anderson, Plott, Shimomura, and Elbaz (2004), and Plott (2001), but with strategically chosen transformations. The basic structure is one of perfect complements in the sense that agents have no utility for one of the commodities and the other two are perfect complements. The preferences are illustrated in Figure 1.

In particular, the preferences and initial endowments were chosen such that in all experiments there existed a unique, interior competitive equilibrium. More importantly, the preference parameters and initial endowments were chosen such that the classical model captured by equation (7) predicts that the prices will diverge from the interior competitive equilibrium from any non-equilibrium initial price vector, and do so in predictable directions.

As will be discussed later, the prediction of the classical model depends importantly upon the preference parameters and the initial endowments. See Appendix A for a discussion of the general class of models from which the experimental parameters were chosen. In all experiments reported the unique, interior, competitive equilibrium is unstable according to the classical model. The nature of the instability depends on the preference parameters and initial endowments. Under one set of endowments, the classical model predicts divergence in a clockwise direction in two-dimensional price space and under a second set of endowments the classical model predicts divergence in a counter clockwise direction. To capture this fundamental difference in predictions we have indexed experiments and parameter types as “Clockwise” and as “Counter Clockwise”. The specific magnitudes of the utility parameters and the endowments are shown in Table 1.

Table 1: PREFERENCES AND ENDOWMENTS				
	Type $i = 1,2,3$	$U^i(x_i, y_i, z_i)$ (in cents)	endowments $\omega_i = (x_i, y_i, z_i)$	Remarks
Clockwise				
	1	$700 \min \{3y/40, z/800\}$	$\omega_1 = (0, 0, 800)$	The classical model predicts divergence with tendencies in a clockwise direction.
	2	$700 \min \{x/20, 3z/800\}$	$\omega_2 = (20, 0, 0)$	
	3	$700 \min \{3x/20, y/40\}$	$\omega_3 = (0, 40, 0)$	
Counter Clockwise				
	1	$2100 \min \{y/120, z/800\}$	$\omega_1 = (0, 40, 0)$	The classical model predicts divergence with tendencies in a counter clockwise direction.
	2	$2100 \min \{x/20, z/2400\}$	$\omega_2 = (0, 0, 800)$	
	3	$2100 \min \{x/60, y/40\}$	$\omega_3 = (20, 0, 0)$	

B. Market Organization

The creation of the markets required many operational decisions. Prices of units of X and Y are quoted in the number of units of Z to be taken in exchange for a unit of X or Y. That is, Z is the numeraire. Notice that the endowments of Z are much greater than the endowments of the other two commodities. This reflects the need for prices to be attainable as ratios of Z for the other commodity, and to do that finely divisible units of Z must exist. Otherwise, the integer constraint would substantially reduce the number of feasible prices.

Two markets exist: an X market and a Y market. Since Z is the numeraire there is no Z market per se. Thus in the X market prices are quoted in terms of the number of Z that will be exchanged for a unit of X and prices in the Y market are quoted in terms of the number of Z that will be exchanged for a unit of Y.

The experiment is divided into periods of fixed time length in minutes. At the beginning of each period each agent is given an endowment as indicated in Table 1. The length of periods varied, with the first few periods in an experiment being longer than those later. This procedure is often employed in complex experiments because traders require time to learn about the trading technology, sources of information, etc. but after such skills have been acquired the periods can be shortened.

The markets were conducted through an electronic market place developed by the Caltech Laboratory for Experimental Economics and Political Science, (EEPS), called Marketscape. This market platform supports multiple, simultaneous, continuous markets. The markets had open (public) books in which bids and asks are placed if they are not at levels that would automatically trigger a trade by meeting the conditions of some previous bid or ask. The bids are exposed to the market from highest price to lowest, while asks are exposed from lowest to highest. Bids and asks remain in the book throughout a period unless expired, cancelled, or executed in a trade. In addition all data from all trades are available for viewing in continuous time through both a periodically updated graph and from a listing of data of all trades. All traders had access to these data throughout the experiment.

When a trade took place, the transaction was immediately recorded and units of inventory and money were transferred between trading parties. It is important to note that this continuous, double auction institution means that trading will take place at disequilibrium prices. Multiple prices will exist over a period. This feature will become clear and important when viewing market data generated in the experiments. This institution embodies the essence of a non-tatonnement mechanism and is thus much different from classical descriptions in which all trades take place at the same price and that price is an equilibrium price. There is no “Walrasian auctioneer” in these markets; they are totally decentralized.

Experimental considerations, and in particular the potential earnings of subjects, required the imposition of minimum price floors. Notice from the parameters in Table 1 that if the allocation approaches a boundary, with one of the prices equal to zero, then the agent with endowment of that commodity would have zero income from the experiment. The consequent potential loss of experimental control suggested that price floors be implemented. The prices of neither X nor Y could go below five Z. Thus, in the markets prices are bounded away from zero but so long as prices are on the interior there are no operating constraints on what they might be.

4. Competitive Model and Classical Dynamics

Application of the competitive model produces the excess demand equations found in Table 2. Individual demand functions are computed under the hypothesis that the agent takes the quoted price as given and then chooses quantities subject to the implied budget constraint and initial endowments. The individual demand functions are then summed and the total of initial endowments subtracted to get the excess demand functions.

Equilibrium is computed by simultaneously setting all excess demand functions equal to zero as reflected in the principle that at equilibrium, market demand equals market supply. For economies with one of each type of agent the excess demand functions are stated in Table 2.

	$E_X(P_X, P_Y)$	$E_Y(P_X, P_Y)$	$E_Z(P_X, P_Y)$
Clockwise	$\frac{60P_X}{40 + 3P_X} + \frac{40P_Y}{P_X + 6P_Y} - 20$	$\frac{800}{60 + P_Y} + \frac{240P_Y}{P_X + 6P_Y} - 40$	$800 \left(\frac{P_X}{40 + 3P_X} + \frac{60}{60 + P_Y} - 1 \right)$
Counter Clockwise	$\frac{800}{120 + P_X} + \frac{60P_X}{3P_X + 2P_Y} - 20$	$40 \left(\frac{P_X}{3P_X + 2P_Y} + \frac{3P_Y}{20 + 3P_Y} - 1 \right)$	$800 \left(\frac{120}{120 + P_X} + \frac{P_Y}{20 + 3P_Y} - 1 \right)$

Of course the competitive equilibrium is defined as the prices and quantities for which excess demands equal zero. Thus, by setting to zero the equations in Table 2 and solving, we find the competitive equilibrium for both sets of parameters. The solutions for both the set of clockwise parameters and the set of counter clockwise parameters are given in Table 3. There the equilibrium prices, quantities, and incomes for both sets of parameters are stated. The scalar transforms the numbers into cents that subjects received.

	Type i = 1,2,3	Incomes (times a scalar)	Final allocations (x_i, y_i, z_i)	Prices
Clockwise				
	1	.75 (700)	(0, 10,600)	(40, 20, 1)
	2	.75 (700)	(15,0,200)	
	3	.75 (700)	(5,30,0)	
Counter Clockwise				
	1	.25 (2100)	(0,30,200)	(40, 20, 1)
	2	.25 (2100)	(5,0,600)	
	3	.25 (2100)	(15,10,0)	

Much of the design is driven by the predictions of the classical models of dynamics represented by the system of equations (7). Shown in Figure 2A and Figure 2B are the phase diagrams resulting from (7) for the parameters given in Table 3. These diagrams

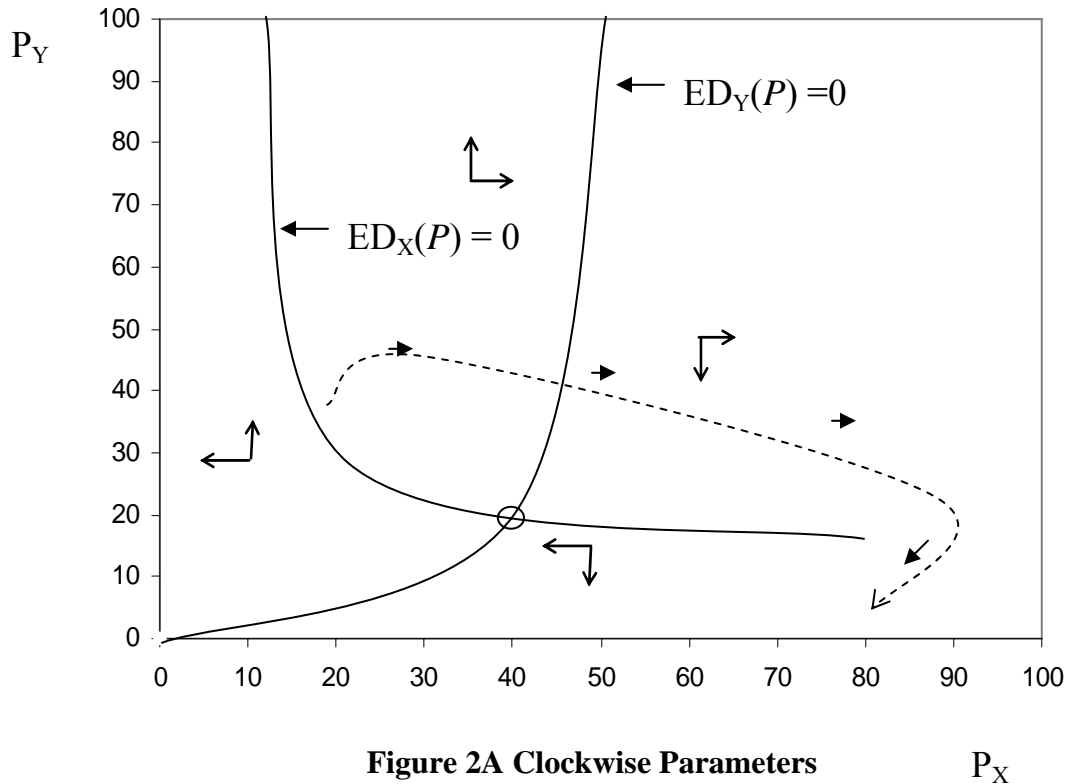

Figure 2A Clockwise Parameters

P_X

show the pairs $P = (P_X, P_Y)$ for which the excess demand are zero for commodity X and commodity Y respectively. That is, the curve $E_X(P) = 0$ in Figure 2A for example, is the pairs of prices for which the excess demand of X is zero in the clockwise parameter case, and curve $E_Y(P) = 0$ shows the pairs of prices for which the excess demand for Y is zero. These curves divide the space into regions for which the excess demand for X is positive (negative) so price pressure on X is up (down) according to theory. And the space is also divided with respect to areas in which the excess demand for Y is positive (negative) so the price pressure on Y is up (down) according to the theory. These regions thus indicate the direction of movements of price pairs as predicted by the theory over the course of the experiment. These predictions of price change directions are shown by the small arrows. The dashed line is a simulated path.

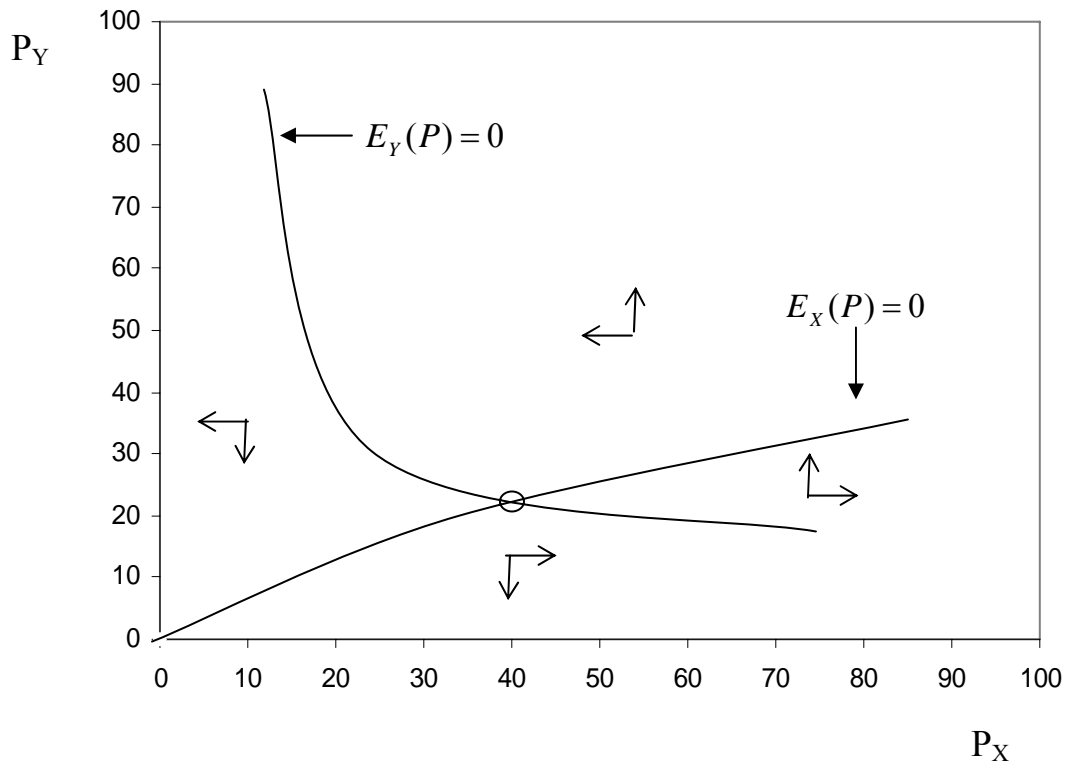

Figure 2B Counter Clockwise Parameters

Figure 2B contains a similar illustration for the Counter Clockwise parameters. Notice that the position and shapes of the curves are different. More importantly, the resulting dynamics predicted by this model are different. In the clockwise case, the prediction is for the prices to move in a clockwise direction in (P_x, P_y) space, and in the counter clockwise case, the predicted directions of movement is the opposite.

The unique interior equilibrium of this model is shown by the center dot. In both cases, the two equations are simultaneously satisfied at the point $P^e = (40, 20)$. It is the competitive equilibrium. It is the unique interior point at which both markets are in equilibrium simultaneously. This equilibrium point is predicted by all models. However, the exact dynamics, the paths in relationship to the equilibrium, differs from model to model.

Notice that the dynamics pushes price toward the origin, $(0, 0)$. That is the case for both the clockwise and counter clockwise parameters. For several experiments, small price floors were imposed to prevent outcomes where subject earnings could be zero. When

the price floor existed, the pair of minimum prices create a stationery “sink” from which prices cannot move. Without the floors the constraint that prices could not be negative created a point at (0,0) from which the only possible movement is along an appropriate axis.

5. Procedures and Experimental Design

Six separate experiments were conducted, all at the California Institute of Technology in the Laboratory for Experimental Economics and Political Science (EEPS) between November 2002 and July 2003. The continuous time double auction multiple markets were implemented using Marketscape as described in the sections above. Each experiment consisted of a number of subjects modulo 3, as we require that there be an equal number of subjects of each type. The actual number of subjects in the experiments ranged from 9 to 18. Participants included Caltech undergraduate and graduate students, as well students from Pasadena City College, many of whom were familiar with the software from previous (unrelated) experiments, but who did not necessarily have any training in economics.

Types were assigned sequentially to subjects as they logged into the software, and the order in which this occurred was essentially random. Subject payments averaged about \$40.00 per subject per experiment. Experiments lasted no more than three hours. Upon arrival in the laboratory, subjects were given written instructions; including both a numeric table and a graphical display of indifference curves that represented their induced preferences. In addition, we included an unrelated payoff table that was used to illustrate how to read their true payoff table (which differed across subjects).

Each experiment began with a practice trading period which served several purposes. It allowed subjects to become acquainted with the computers and software, so that they were comfortable with how to execute bid and ask offers before the paid portion of the experiment began. It also allowed time for the subjects to study their payoff information. In order to implement an initial price, we requested that all trades in the practice period

take place at a price of 25z.⁶ This essentially provided a focal point for prices at the beginning of the first actual period, and worked effectively to control the initial conditions. That is, prices in the experiments tended to start at (25,25).

Following the practice period, each experiment consisted of a number of trading periods, ranging from 10 to 14 periods per session. Each period, in turn, lasted between 8 and 18 minutes. At the end of each period, subjects were paid in experimental currency (francs) computed from the final holdings via the utility function. Then all inventories were cleared, and endowments were reset to their original values before the start of the subsequent period. To avoid any “last period” effects, the final period was not announced as such until *after* it had concluded. After the close of the final period, earnings in francs were tallied and converted to dollars via a conversion factor. Subjects were then either paid in cash before they left the laboratory, or else checks were mailed to them shortly thereafter.

Two primary treatments were used in the experimental design: clockwise (C) and counterclockwise (CC). The utility functions and endowments of each type of agent for the two treatments are given above. The following Table summarizes our experimental design.

TABLE 4: Experimental Design

Treatment	Date	Periods	Interior Periods*	N	Experienced Included
I. Clockwise	11/27/2002	10	1-4	18	No
	12/11/2002	14	1-12	12	No
	7/17/2003	11	1-6	18	Yes
II. Counterclockwise	1/30/2003	12	2-7	15	Yes
	4/28/2003	9	3-6	15	Yes
	6/20/2003	19	8-16	9	Yes

*Periods in which price pairs (P_x, P_y) are away from the boundary of the price space

6. An Illustration of the Market Behavior

Figures 3A and 3B are included here to preview the patterns of results. These figures also motivate how the data are treated for estimation purposes.

⁶ We did not do this in the first session, experiment 021127.

Figure 3A contains all transactions in both markets displayed as a time series. The variability of individual transactions is clear from the figure. Notice that the transactions in different markets take place at different times meaning that at any moment in time there is no “price pair” in the sense required by the models. Thus, prices at an instant in time as required by the dynamic models must be computed from some intermediate model or statistical model. Our choice is to define prices as the mean price over each 10-trade block. For tests that are robust to such asynchrony, such as the distance measure discussed and used in the next section, we use the original, unaveraged data.

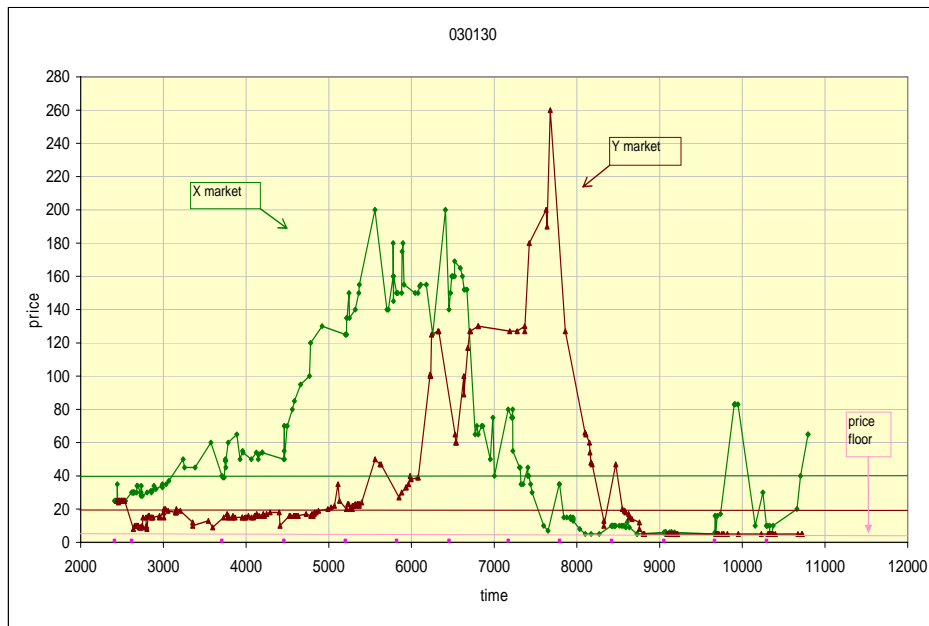

Figure 3A Transaction Price Time Series: Experiment 030130

There is also the issue concerning which concept of time to use. Should time be incremented according to the clock time of each trade, or should some other measure of time be used? We used the ordinal measure of time that is updated after each trade in either market. However, for some purposes, time is updated only after a trade in “own” market.

Because of the exploding cycles in price space produced by the experiment, prices inevitably move near the boundaries of the price space. This causes a number of

problems. For example, the potential lack of income if prices are zero may cause subjects to lose interest in the experiment. For this reason the price floors were introduced. But the price floors, and boundaries in general, create data processing problems. At the extreme, when prices are at the boundary, prices are no longer allowed to adjust in the direction of the boundary. More generally, near the boundary, the error term becomes one-sided and the normality assumption is violated due to the boundary. In the results below, we censored trades where prices are near the boundary of the price space. Again, for tests that are robust to this constraint, such as the clockhand model, we use the full, uncensored data.

The cyclical movement of prices is evident in the individual transactions data but other patterns are also worthy of note. In particular, prices seem to show “no movement” for long periods of time, followed by sudden movements. This type of property is not predicted by any of the models because it has the property that when the model system is in greatest disequilibrium no movement takes place but when movement starts, and the level of disequilibrium is reduced, the movement speeds. Thus, this feature of the data can induce model error even when the model captures many of the other features of the movement.

Figure 3B illustrates the movement of average prices in a period in relation to the phase diagram and the predicted dynamics of the classical model. As can be seen, the general pattern movement is consistent with the classical model. In neither figure does the movement appear to be toward the equilibrium. Furthermore, the general directions of the movement are those predicted by the model.

In the next section, the impressions of these two figures are demonstrated statistically. However, the classical model will not be the most accurate from a rigorous point of view. Close examination of Figure 3B contains hints of problems. Notice that when the prices begin to move the movement is down and to the right as predicted. But then in period, three there is a slight upward movement in the price of Y and then, in the following period there is a jump of phase. Continuing to follow the time series in the figure, notice that the price of Y turns down when the model suggests that it should still go up. Thus,

many subtle patterns exist in these data, some of which are captured more completely by an alternative to the classical model.

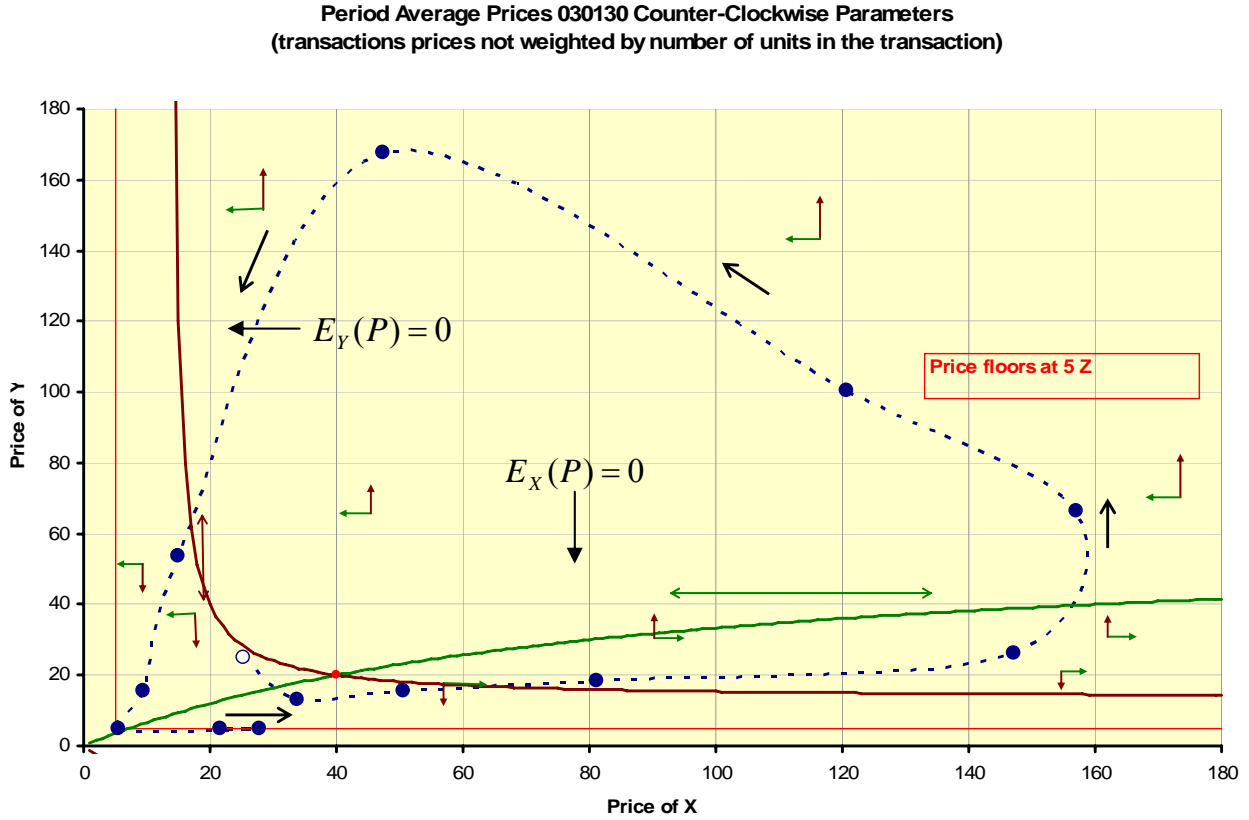

Figure 3B Average Period Prices and Phase Diagram: Experiment 030130

7. Results

An impression of the market behavior that leads to the results is gained from Figure 4. Shown there is the time series of average prior price for all periods of all experiments. The average price of X is on the horizontal axis and the average price of Y is the vertical axis. The upper panel contains all (theoretically) clockwise experiments and the counterclockwise are all the lower. As can be seen, the movements are in the general direction predicted by theory. Indeed, an understanding of all of the major results can be gained from this figure.

The first two results address the problem that motivated the experiments. Is it the case that the markets necessarily converge toward the interior competitive equilibrium? The

answer given by the data is “no”. The movement of the markets is not in the direction of the competitive equilibrium and instead exhibit properties of movement away from the interior competitive equilibrium (Result 1), and do so in directions consistent with the prediction of the classical model (Result 2).

With the initial questions answered the analysis moves to consider specific models of the dynamic principles that might be at work. The first test (Result 3) is the classical model nested in equations such as (5). While the model receives considerable support, the data exhibit several rather clear inconsistencies with this model suggesting that variations of the model might improve its success. The next two results (Result 4 and Result 5) reflect our attempts to isolate where the improvements might reside by having the dynamics depending on prices as in equations (1) and (2). Result 6 demonstrates that the price adjusted models in the form of equation (2) appear to be the best for explaining what we observe.

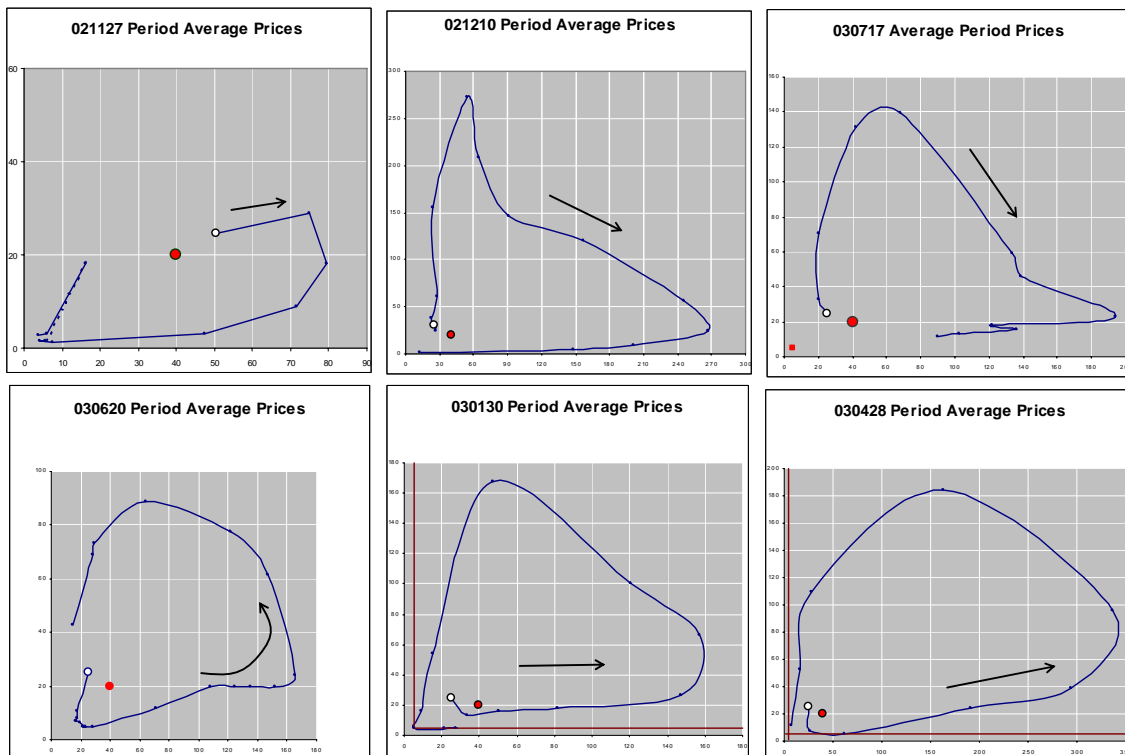

**Figure 4. Average Period Prices All Experiments:
Clockwise Parameters Upper Panel and Counterclockwise Parameters Lower Panel**

The initial questions related to the directions of movement of prices. Are the prices moving, perhaps slowly, in the direction of the interior equilibrium and are they doing so by moving in the directions predicted by the classical model. The next two results address those questions. Result 1 demonstrates that the movements are away from the equilibrium price. Result 2 demonstrates that the directions of the movements, clockwise or counter clockwise, are as predicted by the classical model.

Result 1. Prices diverge from the interior equilibrium. That is, over time the prices move further away from the equilibrium price pair in Euclidean price space.

Support.

The question was investigated by regressing distance from the equilibrium on time. Distance was measured as the Euclidean distance of pair of prices $P = (P_X, P_Y)$ and the equilibrium $P^e = (40, 20)$. A positive coefficient on time suggests that prices are moving away from equilibrium in the X-Y price space.

Because of the bias introduced to the distance metric at the boundaries, however, we censored the data when prices move near the boundary of the price space. The periods used in the analysis are presented in Table 4.

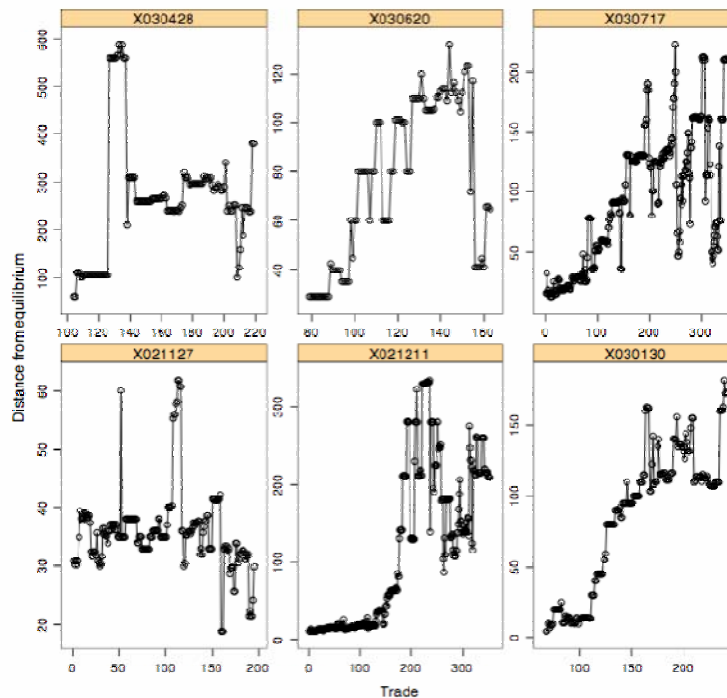

Figure 5: Distance from equilibrium separated by session.

Figure 5 presents such scatter plots for each session. The vertical axis shows the distance of the price from the equilibrium price and the horizontal axis represents the order of the trade. The figures carry the suggestion that as the volume of trades increases over time the prices get further away from the equilibrium price. Table 5 shows the estimates from the regression. The regressions make precise the impressions from the figures. The regression is a fixed effects model in which a common slope is assumed for each session, whereas the intercept is allowed to vary from session-to-session.⁷ The estimates show that prices are moving away from the equilibrium on average. The movement away from the equilibrium price is on average 0.568 with each trade and highly significant.

Table 5: Regression of distance on time.

	Estimate	Std. Error	t value	Pr(> t)
(Intercept)	-19.78881	4.60104	-4.301	1.83E-05
Trade.Time	0.56764	0.01999	28.392	< 2e-16
021211	35.73516	5.4225	6.59	6.43E-11
030130	16.97038	6.15592	2.757	0.005922
030428	193.17394	6.93367	27.86	< 2e-16
030620	28.16805	7.56971	3.721	0.000207
030717	12.66667	5.42042	2.337	0.019603

To confirm that this result is not an artifact of the censoring, we conducted a paired t-test on the beginning and end prices (uncensored time series) of the market over the 6 sessions. The test asks if the beginning prices are closer to the equilibrium prices than are the ending prices. For the 6 pairs of prices, the mean distance was 18.01 (in units of Z) at the beginning of the experiment, and 36.89 at the end ($t = 5.59$). The test is significant at $p = 1.26e-3$ for a one-tailed test.

Result 2. The directions of price movements are consistent with the classical dynamics model.

Support.

In a sense, a brief glance at the time series in Figure 3B suggests an answer to the question and Figure 6 provides a more complete view. We apply two nonparametric

⁷ A mixed effects models also show that the coefficient on the interaction term “Trade.Time” is significant. Individual session regressions show that all sessions have positive and significant sign on Trade.Time,

tests: (1) a “clockhand” model, and (2) a “sign test”. The “clockhand” test simply measures the angle in price space between where the data started relative to the equilibrium (with the equilibrium centered on (0,0) and where the prices are at any instant of time. A line segment connects the data point with the equilibrium and as the data moves the line segment rotates around the equilibrium. The model measures the angle between the original line segment and the line segment that connects the equilibrium to the data at any point in time. (See Anderson, et. al., for a geometric description).

Because the clockhand test is a non-parametric test that is robust to both boundary restrictions and asynchronous trades, we are able to use the entire time-series for all the sessions.

Figure 6 shows the cumulative angle changes in all 6 sessions. There is a clear separation between the clockwise and counter-clockwise treatments. In addition, note that 2 of the counterclockwise treatments resulted in cumulative angle changes greater than 2π . I.e., in two of the sessions, the price orbit completed a complete cycle.

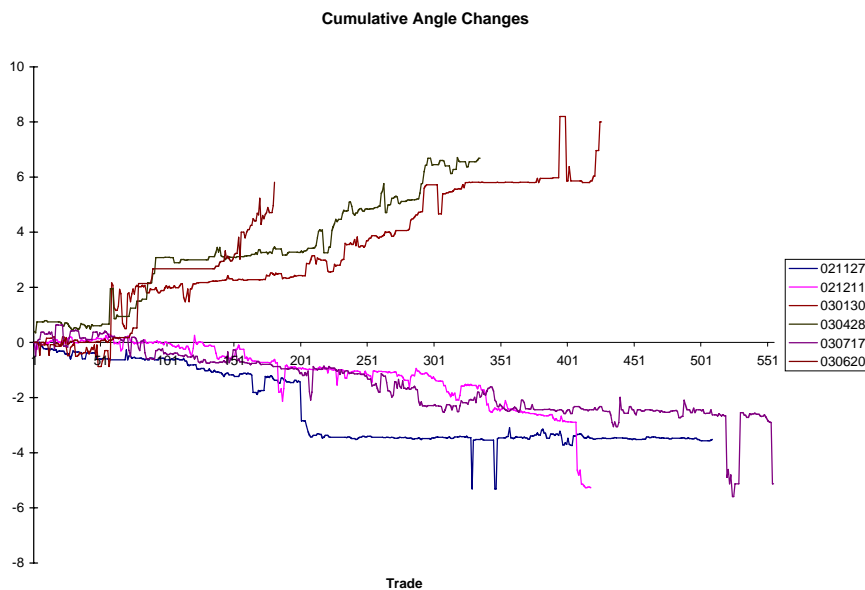

Figure 6: Clockhand model. Note that there is a clear separation between the clockwise and counterclockwise treatments, in accordance to theory.

except for session 021127. That session was the only session where prices did not begin near (25,25), and proceeded to crash almost immediately to $P_y \sim 0$.

The sign test is a binomial test with $p=1/4$ that counts the instances where the sign of the price change in a given trade matches the sign of the excess demand in both markets.

That is, whether $\text{sign}(P_{X,t} - P_{X,t-1}, P_{Y,t} - P_{Y,t-1}) = \text{sign}(E_X(P_{t-1}), E_Y(P_{t-1}))$.

This test is sensitive to both boundary effects *and* asynchronous trades; therefore the censored and averaged data was used. Pooling over all sessions, there were a total of 124 data points, of which in 52 trials the price change was predicted correctly by excess demand in both the X and Y markets. Compared to a random prediction, the test was significant at a $p = 4.112e-5$.

In a sense both Result 1 and Result 2 are implicitly answered by Result 3, which suggests that the classical model has considerable explanatory power. Result 3 makes that clear while simultaneously listing inaccuracies of the model that motivate a deeper investigation of the dynamics. The classical model (equation (6)) is nested in the more general system of equations (5). Since all prices and allocations are observable to the experimenter, so are the price changes and the excess demands as defined by the competitive model. That allows us to directly estimate the parameters of the dynamic models and examine the structure of the error terms.

Several operational assumptions were made as were outlined in the section above. All econometric models were estimated in OLS and mixed effects⁸. The results are generally similar, with the few differences we shall discuss.

In order to estimate the classical model given the experiments data, we will replace (5) with a set of stochastic difference equations for transaction price changes

$$P_{t+1} - P_t = a + AE(P_t) + \varepsilon_{t+1}.$$

The noise term ε_{t+1} is assumed to be mean zero and uncorrelated with past information (order flow, transaction volume, and prices).

Equivalently, we can write the above as (8).

⁸ Seemingly Unrelated Regression (SUR) was also performed. The results were nearly identical to the OLS equations—suggesting that disturbances between the markets are not correlated.

$$(8) \quad \begin{aligned} \dot{P}_x &= a_{session} + a_{XX} E_X(P) + a_{XY} E_Y(P) \\ \dot{P}_Y &= a_{session} + a_{YX} E_X(P) + a_{YY} E_Y(P) \end{aligned}$$

Clearly, the classical model is nested in the estimated equations. That is, the classical model holds that the intercept term should be zero and the diagonal elements positive. The off diagonal elements should be zero.

RESULT 3: The Classical Model receives substantial support but has challenging inconsistencies with the data.

Support

The support and analysis involves several different types of arguments. The first analysis comes from the estimates of the elements of the A matrix from equation (5) and equations (8) These results are described as (i) below. Two properties are of interest here. The first are the signs of the diagonal elements and the second, included as (ii) below, are the off diagonal elements. As shown in the support the diagonal elements have the predicted property (both positive) but the off diagonal elements do not, and so are investigated further under (ii). To ensure that our estimates are sensible, we ran further analysis to see if they matched qualitatively with our data. First, the eigenvalues of the differential equations we estimate from the data around the equilibrium can be used to check the convergence or divergence properties of the system. The eigenvalues also suggest a difficulty for the model as described in (iii), which lead to a more detailed investigation through simulation of the estimated model. These results are presented in (iv) along with the phase diagrams, which give a better view of the overall properties (and not just the local properties as given by the eigenvalues). Simulated paths from various initial values are also included in the section, which concludes with a list of properties found in the data that differ from those predicted by the model.

(i) Estimates of A matrix coefficients and diagonal elements.

We estimated separately the equations for the X and Y markets and include the estimates as Table 6A and Table 6B⁹.

⁹ As was discussed above, because of issues arising from trade asynchrony and price boundaries, we use the censored and averaged time series data.

Table 6A: $\dot{P}_x = a_{session} + a_{XX} E_X(P_X, P_Y) + a_{XY} E_Y(P_X, P_Y)$

	Estimate	Std. Error	t value	Pr(> t)
(Intercept)	-1.4283	1.6154	-0.884	0.37843
$E_X(P)$	0.8697	0.2557	3.401	0.00092
$E_Y(P)$	-0.1101	0.1036	-1.063	0.29008
021211	2.788	1.9403	1.437	0.15343
030130	2.2848	2.2488	1.016	0.31173
030428	4.9783	2.4477	2.034	0.04425
030620	0.2193	2.6946	0.081	0.93528
030717	2.8355	1.9617	1.445	0.15103

Residual standard error: 5.837 on 116 degrees of freedom
Multiple R-Squared: 0.1578, Adjusted R-squared: 0.107
F-statistic: 3.104 on 7 and 116 DF, p-value: 0.004882

Table 6B: $\dot{P}_y = a_{session} + a_{YX} E_X(P_X, P_Y) + a_{YY} E_Y(P_X, P_Y)$

	Estimate	Std. Error	t value	Pr(> t)
(Intercept)	1.63893	1.14411	1.432	0.15469
$E_X(P)$	-0.49751	0.1811	-2.747	0.00697
$E_Y(P)$	0.20218	0.07338	2.755	0.00681
021211	-0.70852	1.37422	-0.516	0.60713
030130	-1.07071	1.59272	-0.672	0.50276
030428	3.7733	1.73365	2.177	0.03154
030620	-0.77622	1.90849	-0.407	0.68496
030717	-1.45572	1.38941	-1.048	0.29694

Residual standard error: 4.134 on 116 degrees of freedom
Multiple R-Squared: 0.2572, Adjusted R-squared: 0.2123
F-statistic: 5.737 on 7 and 116 DF, p-value: 1.024e-05

On the face of it, the classical model appears to predict well. Results from Table 6A and Table 6B show that the markets move in the direction of their own excess demand. That is, the classical prediction that a_{XX} and $a_{YY} > 0$ are both properties of the adjustment process. The direction of divergence is also consistent with those observed in the data. Notice also that the intercept term is not different from zero, as it should be according to the classical model. Several anomalies, however, suggest that the explanatory power of the classical model can be improved upon.

(ii) Off- diagonal property tests

First, the asymmetry of the A matrix is puzzling. Whereas both diagonal elements of the A matrix are positive and significant, only one of the off-diagonal elements is significant.

It is furthermore larger than the A_{YY} coefficient, which would suggest that price changes in the Y market respond proportionally more to the excess demand in the X market rather than the Y market, which is perplexing.

(iii) Eigenvalues

For the counterclockwise condition, the eigenvalues around the equilibrium $(P_x, P_y) = (40, 20)$ are $(0.170065, 0.0193102)$, which are both positive real roots. This implies that the path of differential equation simply diverges, but does not diverge cyclically as predicted.

For the clockwise case, the eigenvalues are the complex roots $(0.0471 + 0.0325i, 0.0471 - 0.0325i)$. This implies that the path of differential equations cyclically diverges as predicted.

(iv) Phase Diagrams and Simulation

The phase diagrams and simulation suggest the nature of the problems with the model. The dynamics themselves have room for improvement. Calculation of the phase diagram using the coefficients measured econometrically shows that the phase diagram of the system does not capture the behavior of the experimental data. The phase diagrams from measured coefficients are in Figure 7A and 8B.

Finally, a simulation confirms the behavior of the estimate of the classical system. The simulations are contained in Figure 8A and Figure 8B. These dynamics are clearly contradicted by our data in both treatments.

RESULT 4. Price changes are influenced by prices directly in addition to the dependence through the excess demand functions.

Support.

The table of estimates of a model that has the adjustment linear in prices is included as Appendix B. The price coefficients are positive suggesting that the price variables pick up some, possibly nonlinear movement. This finding motivated a more serious examination of models in which the adjustment matrix contained prices. The next results followed from that examination.

Theory suggests two ways in which prices might enter the adjustment process while preserving the general theory of the dynamics. The first is captured by the system of equations (4). It is the theory that the adjustment matrix is the inverse of the Jacobian matrix of the excess demand functions. Since the theoretical excess demand functions are known to us we can impose the equations directly on the measurements. The questions lead to estimation of the equations:

$$(9) \quad \dot{P}_X = a_{session} + a_{XX}(-J_{XX}^{-1}(P_X, P_Y))Z_X(P_X, P_Y) + a_{XY}(-J_{XY}^{-1}(P_X, P_Y))E_Y(P_X, P_Y)$$

$$\dot{P}_Y = a_{session} + a_{YX}(-J_{XX}^{-1}(P_X, P_Y))Z_X(P_X, P_Y) + a_{YY}(-J_{YY}^{-1}(P_X, P_Y))E_Y(P_X, P_Y)$$

As is clear from the next result the theory that the markets follow the Newton method of dynamic solutions to equations is substantially rejected by the data.

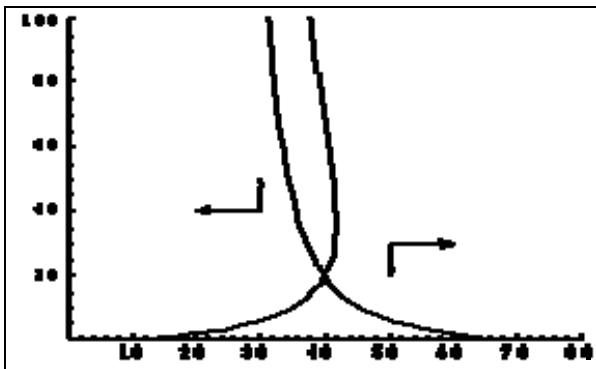

Figure 7A: Phase diagram for the Clockwise Treatment

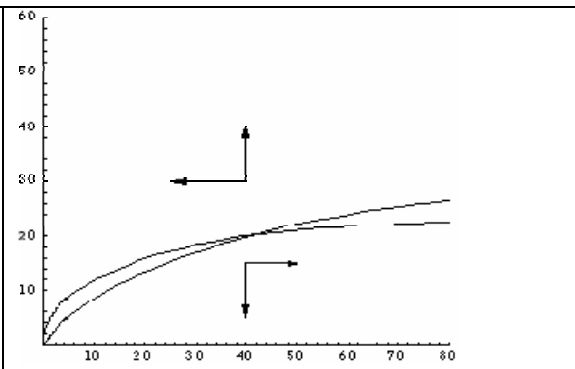

Figure 7B: Phase diagram for the Counterclockwise Treatment

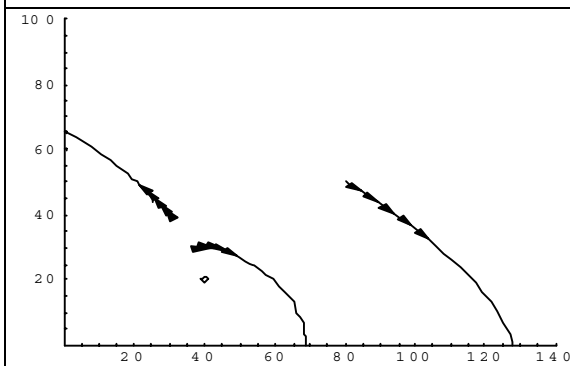

Figure 8A Simulation of the Clockwise treatment with initial prices (40,30), (30,40), and (80,50).

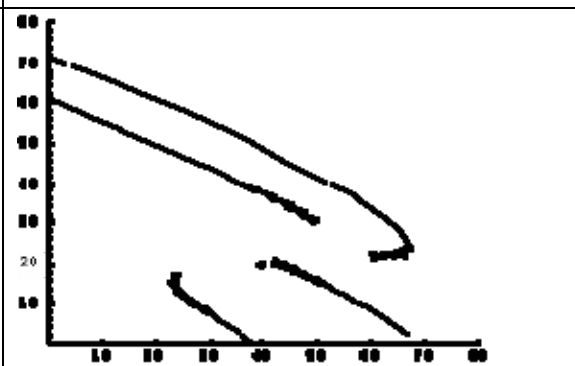

Figure 8B : Simulation of the Counterclockwise treatment with initial prices (24,16), (43,20), (50,30), and (60,22).

RESULT 5. Neither the Newton nor Generalized Newton model produce explanatory improvements over the classical model.

Support.

Equations (9) were estimated following the procedures employed elsewhere when dealing with the data. Table 7A and Table 7B show the estimates for the Newton model. Notice that the model does not fit the data well. The only coefficient that is significant is the dummy on Session 030428, which has an outlier (also reflected in the A matrix estimates). Essentially, we find no support for the Newton model. The Global Newton model produces similar estimation results as the Newton model.

That the Newton method and its relatives do not fit the data reflects the fact these models all predict convergent behavior in the price space that is not observed in our data. (See Appendix C.)

Table 7A:

$$\dot{P}_x = a_{session} + a_{xx}(-J_{xx}^{-1}(P_x, P_y))E_x(P_x, P_y) + a_{xy}(-J_{xy}^{-1}(P_x, P_y))E_y(P_x, P_y)$$

	Estimate	Std. Error	t value	Pr(> t)
(Intercept)	-0.171909	1.3836516	-0.124	0.901
$(-J_{xx}^{-1}(P))E_x(P)$	0.0008175	0.0006682	1.224	0.224
$(-J_{xy}^{-1}(P))E_y(P)$	0.0005572	0.0007719	-0.722	0.472
021211	1.7212789	1.7195688	1.001	0.319
030130	0.0833624	2.0192343	0.041	0.967
030428	3.8098075	2.3057904	1.652	0.101
030620	-0.477877	2.5509733	-0.187	0.852
030717	1.9256433	1.7269667	1.115	0.267

Residual standard error: 6.029 on 116 degrees of freedom
 Multiple R-Squared: 0.1015, Adjusted R-squared: 0.04733
 F-statistic: 1.873 on 7 and 116 DF, p-value: 0.08017

Table 7B: $\dot{P}_y = a_{session} + a_{yx}(-J_{yx}^{-1}(P))E_x(P) + a_{yy}(-J_{yy}^{-1}(P))E_y(P)$

	Estimate	Std. Error	t value	Pr(> t)
(Intercept)	-3.35E-01	1.01E+00	-0.332	0.740721
$(-J_{yx}^{-1}(P))E_x(P)$	1.01E-05	9.18E-05	1.101	0.27327
$(-J_{yy}^{-1}(P))E_y(P)$	-1.65E-04	3.83E-04	-0.431	0.667493
021211	1.52E+00	1.28E+00	1.192	0.235751
030130	1.80E+00	1.47E+00	1.223	0.223785
030428	5.97E+00	1.67E+00	3.579	0.000505
030520	1.08E+11	1.86E+00	0.583	0.560907
030717	4.63E-01	1.26E+00	0.367	0.714282

Residual standard error: 4.404 on 116 degrees of freedom
 Multiple R-Squared: 0.157, Adjusted R-squared: 0.1061
 F-statistic: 3.086 on 7 and 116 DF, p-value: 0.0051

The analysis above left us with still one more unexplored path suggested by the data, and that is a model in which the dynamics operate on the percentage change in prices as opposed to the changes in prices directly. That is, if prices are low it takes a greater difference in excess demand to generate a certain absolute price change than if prices are high. That dynamics of the theory are captured by the system of equations (2) or as found in estimated form, equations (3). For purposes of estimation the equations are:

$$(10) \quad \begin{aligned} \dot{P}_x &= a_{session} + a_{XX} P_x E_x(P) + a_{XY} P_x E_y(P) \\ \dot{P}_y &= a_{session} + a_{YX} P_y E_x(P) + a_{YY} P_y E_y(P) \end{aligned}$$

RESULT 6. The Scaled Classical Model has good accuracy and does not have the inaccuracies of the other models.

- (i) the R^2 measures are good relative to other models
- (ii) the estimated A matrix is a diagonal matrix
- (iii) eigenvalue analysis is consistent with observations
- (iv) phase diagrams and simulations are consistent with observed price movements.
- (v) directions of price movements are consistent with the model.

Support.

Table 8A and 8B presents the regression results from the scaled classical model. For additional analysis of individual sessions, see Appendix D. The elements of the result are addressed in order. Basically, the fit of the model is good and, more importantly, the scaled price model solves all of the aforementioned anomalies observed in the classical model as detailed in the parts of the statement of the result.

- (i) It is clear through the R^2 that the scaled price model fits much better than the classical model.¹⁰ An F-test of a full model including both excess demand and price scaled excess demand does not reject the reduced model with price-scaled excess demand only (X

¹⁰ Durbin-Watson tests for serial correlation of the residuals do not reject the null hypothesis ($\rho_x = -0.198$, $p=0.108$, two sided; $\rho_y = -0.007$, $p=0.596$, two sided).

market: $F = 1.9404$, $DF=2$, $p < 0.2$, Y market: $F = 1.9679$, $DF=2$, $p < 0.2$). A Cox-test for non-nested models shows similar results.

(ii) The estimates conform to the predictions of the model. The adjustment matrix is symmetric, with positive diagonals and negative but insignificant off-diagonals.

Table 8A: $\dot{P}_x = a_{session} + a_{xx} P_x E_x(P) + a_{xy} P_x E_y(P)$

	Estimate	Std. Error	t value	Pr(> t)
(Intercept)	-91.4E-01	1.66E+00	-0.55	0.5833
$P_x E_x(P)$	1.48E-02	2.96E-03	5.167	1.00E-06
$P_y E_y(P)$	-5.33E-04	5.57E-04	-0.957	0.3408
021211	1.46E-01	2.12E+00	0.069	0.9451
030130	1.88E+00	2.35E+00	0.802	0.4244
030428	5.65E+00	2.34E+00	2.413	0.0174
030620	-4.16E-01	2.84E+00	-0.146	0.8839
030717	-1.10E-01	2.18E+00	-0.051	0.9596

Residual standard error: 20.81 on 116 degrees of freedom
 Multiple R-Squared: 0.2963, Adjusted R-squared: 0.2538
 F-statistic: 6.977 on 7 and 116 DF, p-value: 6.188e-07

Table 8B: $\dot{P}_y = a_{session} + a_{yx} P_y E_x(P) + a_{yy} P_y E_y(P)$

	Estimate	Std. Error	t value	Pr(> t)
(Intercept)	7.42E-01	1.43E+00	0.517	0.606
$P_x E_y(P)$	-1.43E-03	1.42E-03	-1.007	0.316
$P_x E_x(P)$	1.09E-02	1.73E-03	6.336	4.64E-09
021211	-5.42E-01	1.70E+00	-0.319	0.75
030130	-2.05E+00	1.97E+00	-1.039	0.301
030428	3.33E+00	2.19E+00	1.522	0.131
030620	-1.53E+00	2.44E+00	-0.628	0.531
030717	-1.70E+00	1.65E+00	-1.03	0.305

Residual standard error: 12.28 on 116 degrees of freedom
 Multiple R-Squared: 0.4088, Adjusted R-squared: 0.3731
 F-statistic: 11.46 on 7 and 116 DF, p-value: 5.433e-11

(iii) Eigenvalues

The eigenvalues in counterclockwise are ($0.0477 + 0.0351 i$, $0.0477 - 0.0351 i$).

The eigenvalues in clockwise are ($0.0023 + 0.0018 i$, $0.0023 - 0.0018 i$).

Therefore, the paths have the cyclically diverging property displayed in the data. This property is suggested by the phase diagrams, discussed next.

(iv) Phase Diagrams and simulations

Phase diagrams calculated using estimates in the scaled price model show that they are remarkably similar to those of the classical model with identity adjustment A matrix. The phase diagrams from the estimated matrix are shown if Figure 9A and Figure 9B.

Finally, simulations of price paths given the estimated equations and various initial conditions show cyclical behavior broadly consistent with observed data. These are shown in Figure 10A and 10B.

(v) Direction of Price Movements

The simulations demonstrate that the predicted price movements are in the clockwise and counter clockwise direction, much the same as the classical model. Result 2 demonstrated that the actual price movements were in the predicted direction. Thus, the price movements are in the direction predicted by the model and the prices do diverge from the equilibrium as predicted by the model.

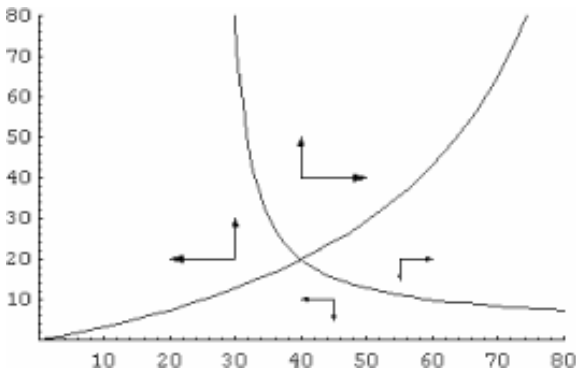

Figure 9A: Phase Diagram for the Clockwise Treatment

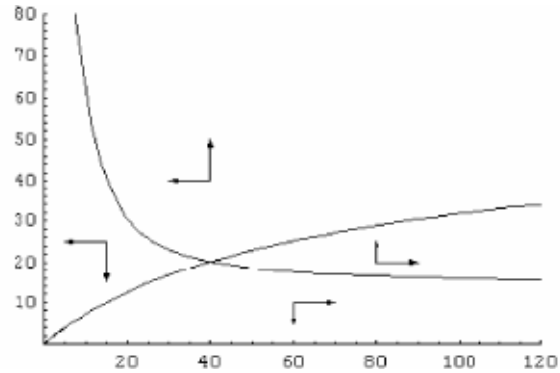

Figure 9B: Phase Diagram for the Counterclockwise Treatment

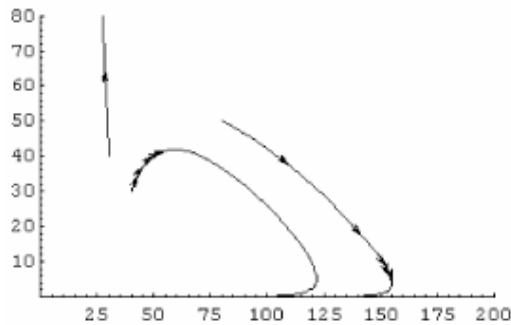

Figure 10A: Simulation of Clockwise Treatment with initial prices (40,30, 30,40, and (80,50).

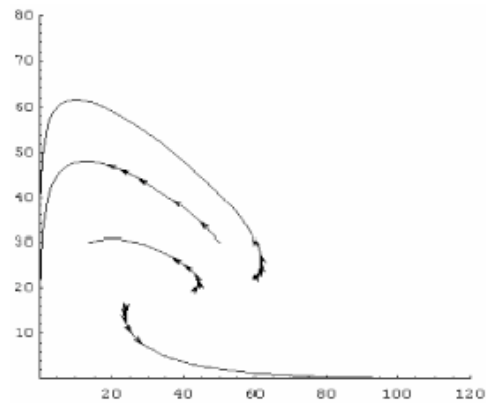

Figure 10B: Simulation of Counterclockwise Treatment with initial prices (24,16), (43,20), (50,30), (60,22).

One final issue needs to be addressed. We can see from the above results that the classical model with price-scaled price changes works well to predict the paths. Yet, the model is based upon a tatonnement story while the actual data are produced by a non-tatonnement process. Can we proceed with a theory founded on tatonnement when we know that the theory will be applied to a non tatonnement world? The results seem to suggest so and the questions that naturally surfaces are why that might be the case and what are the limitations. The next result takes a step toward a resolution of the puzzle. For the environment we study, the answer is that the predictions of the two models are virtually the same.

RESULT 7. The predictions of a tatonnement model and a non-tatonnement model are very similar in these environments.

Support.

We estimate a model in which price adjusts proportional to the scaled instantaneous excess demand (IED). IED is defined as the excess demand function evaluated at the prices at time t and allocations of all agents at time t i.e., $E(P_t, x_t)$, where $x_t = (x_1, x_2, \dots, x_n)$. Tables 9A and 9B present regression results from the above model.

Table 9A: $\dot{P}_{X,t} = a_{session} + a_{XX} P_{X,t} E_X(P_t, x_t) + a_{XY} P_{X,t} E_Y(P_t, x_t)$

	Estimate	Std. Error	t value	Pr(> t)
(Intercept)	-1.3068231	1.5568398	-0.839	0.403
021211	0.6516592	1.9859814	0.328	0.743
030130	1.8842574	2.1967005	0.858	0.393
030428	2.3615645	2.1886043	1.079	0.283
030620	-0.3443601	2.6777363	-0.129	0.898
030717	1.0030917	2.0247707	0.495	0.621
$P_{X,t} E_X(P_t, x_t)$	0.0161753	0.0030177	5.36	4.29E-07
$P_{X,t} E_Y(P_t, x_t)$	-0.0005254	0.0005617	-0.935	0.352

Residual standard error: 19.68 on 116 degrees of freedom
Multiple R-Squared: 0.3706, Adjusted R-squared: 0.3326
F-statistic: 9.758 on 7 and 116 DF, p-value: 1.623e-09

Table 9B: $\dot{P} = a_{session} + a_{YX} P_{Y,t} E_X(P_t, x_t) + a_{YY} P_{Y,t} E_Y(P_t, x_t)$

	Estimate	Std. Error	t value	Pr(> t)
(Intercept)	0.528986	1.433484	0.369	0.7128
021211	-0.955177	1.700771	-0.562	0.5755
030130	-1.937615	1.969266	-0.984	0.3272
030428	4.817582	2.127789	2.264	0.0254
030620	-1.221629	2.436275	-0.501	0.617
030717	-2.128055	1.660322	-1.282	0.2025
$P_{Y,t} E_X(P_t, x_t)$	-0.002276	0.001996	-1.14	0.2566
$P_{Y,t} E_Y(P_t, x_t)$	0.010594	0.001959	5.408	3.47E-07

Residual standard error: 12.29 on 116 degrees of freedom
 Multiple R-Squared: 0.4073, Adjusted R-squared: 0.3715
 F-statistic: 11.39 on 7 and 116 DF, p-value: 6.241e-11

Compared to the estimates of tatonnement in Table 6A and 6B, the IED estimates are qualitatively similar. Diagonal elements a_{XX} and a_{YY} are both positive and significant, but only one of the off-diagonal elements, a_{YX} is significant. In addition, the confidence intervals of the estimated coefficients in the two models overlap.

Figure 11 shows the reason behind this. Namely, the excess demand of tatonnement and that of IED are nearly identical. The similarity of the regressions follow as a result.

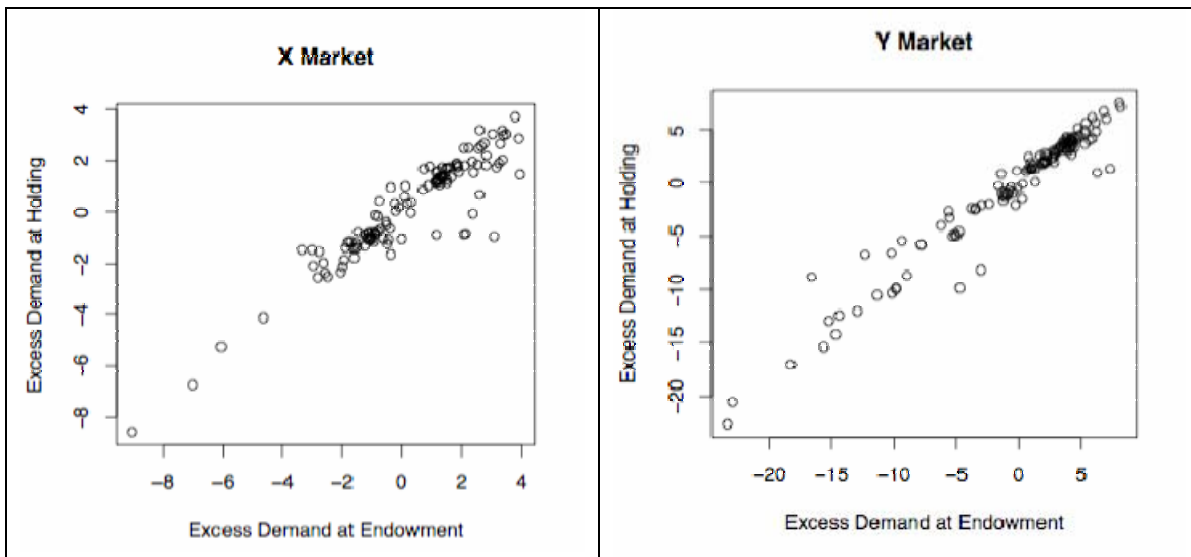

Figure 11: Scatter plot of excess demand evaluated at the endowment and excess demand evaluated at the allocations at time t .

The final result, Result 7, goes to a very deep issue in general equilibrium theory and its applications. For the most part, non-tatonnement theory has not been used in applications because the data that are required in order to adjust the model for disequilibrium trades are seldom available in field examples. Thus, the question becomes whether or not a model based on tatonnement is reliable when it is applied to a non-tatonnement environment. Result 7 says that the predictions of the two models can be very close and this is because the excess demand functions are very close. Of course, exactly why they are close in the experiments is an open question¹¹ but to the extent that this property survives in the field, the theory can proceed with some confidence that it will not be substantially misleading about what is observed.

8. Summary of Conclusions

The experiments permitted the study the properties of market dynamics typically unobservable in markets found in the field. Left to her own nature does not cooperate to create environments required to separate complex theories. The Scarf environment accomplishes that task.

The conclusions are easy to summarize. Prices appear to adjust according to the classical model of dynamics with the following modifications. First, markets adjust at different speeds, so while the adjustment matrix is diagonal, the diagonal elements are not equal. Secondly, the diagonal elements are weighted by the prices. This means that the percentage change in price seems to follow a clear set of principles while the absolute changes in prices are more difficult to capture. Third, while the overall market dynamics are captured by the model, phenomenon such as phase jumps remain to be explained.

¹¹ Hirota (1981, 2004) and Mukherji (2002, pp.86-90; 2003) both demonstrate that the existence of instability in a broad class of models is very sensitive to the initial endowments. Slight changes in initial endowments can produce a stable equilibrium. Such results are relevant because the new allocations that occur due to disequilibrium trades can be analyzed as a different initial endowment and thus the theory suggests that along the path of disequilibrium trades a new, stable equilibrium would be found through the disequilibrium trades. While this issue is beyond the scope of this paper we did solve for the equilibrium given every allocation that evolved during experiments. The result is that relatively few of these equilibria are stable. Of course, if the nature of the equilibrium changes with disequilibrium trades, the empirical property of Result 7 might not be reliable.

From a more general perspective, the results suggest that convergence to an interior equilibrium cannot be guaranteed. The laws of dynamics can produce closed cycles and exploding orbits. Such phenomenon are not simply a theoretical fiction. The actual existence of these phenomena are verified by experiments. Of course, the theory itself can be used to determine the likelihood in field environments. Furthermore, partial equilibrium analysis can be used to measure speeds of adjustment and the percentage change in price can be used to forecast future movements of the system. Finally, the tatonnement model has remarkable predictive power in this non-tatonnement world. Our analysis suggests that the reason is because not much difference exists between the excess demands of the two models. Whether that is a robust result awaits additional experiments.

APPENDIX A: Notes on Experimental Design and Parameters

The parameters chosen for the experiments reflected considerable research on the various possibilities. This appendix provides an overview that attempts to help the reader understand the parameters used and provides those interested with suggestions about additional experiments and tests.

Four parameters are used to form preferences and initial endowments across the experimental series. These parameters $\{\alpha, \beta, \gamma, q\}$ interacted with preferences and endowments. The interactions with preferences are as follows. Notice that α is a scaling parameter for x_2 , β is a scaling parameter for x_3 and γ is a scaling parameter for x_1 . The parameter q operates on individuals to change the value of different goods across the individuals. The functions studied when in parametric form are:

$$U_1(x_2, x_3) = \min [x_2/q\alpha, x_3/\beta]$$

$$U_2(x_1, x_3) = \min [x_1/\gamma, x_3/q\beta]$$

$$U_3(x_1, x_2) = \min [x_1/q\gamma, x_2/\alpha]$$

The choice of experimental design also involves an interaction of the four parameters with initial endowments. The following example illustrates the material that will be presented in the table in the next section. The example is for the case of clockwise unstable parameters that were actually used in the experiments.

$$q = 1/3$$

$$(\gamma, \alpha, \beta) = (20, 40, 800)$$

preferences

$$\text{type one preferences: } \min \{3x_2/40, x_3/800\}$$

$$\text{type two preferences: } \min \{x_1/20, 3x_3/800\}$$

$$\text{type three preferences: } \min \{3x_1/20, x_2/40\}$$

endowments

$$\text{type one endowments: } (\mathbf{x}_1, \mathbf{x}_2, \mathbf{x}_3) = (0, 0, \beta) = (0, 0, 800)$$

$$\text{type two endowments: } (\mathbf{x}_1, \mathbf{x}_2, \mathbf{x}_3) = (\gamma, 0, 0) = (20, 0, 0)$$

$$\text{type three endowments: } (\mathbf{x}_1, \mathbf{x}_2, \mathbf{x}_3) = (0, \alpha, 0) = (0, 40, 0)$$

The predictions for this set of parameters are

(i) $(P_1, P_2) = (\beta/\gamma, \beta/\alpha) = (40, 20)$ where P_i is the price of x_i in terms of x_3 .

(ii) Unstable time path moving in a clockwise direction

Table A1 provides a pattern of parameters that created a background for the specific choice of parameters for implementation. Parameters that theoretically lead to closed cycles and to stable paths have been studied by Anderson, et. al., (2003) and by Plott (2001). While existing studies did not use the parameters in the table, the parameters used in those studies did lead to the same qualitative implications for system behavior as the parameters in the table. Thus, we make no attempt here, to study parameters that theoretically lead to stability or theoretically lead to closed cycles. The question posed

here is whether or not divergence can be observed so the focus was on parameters that theoretically lead to divergence. Those parameters are in the upper left and lower right of the table. As can be seen, the difference resides in the choice of q and the choice of initial endowments.

Table A1: General Parameter Set for Stability Analysis

q	Endowments (γ, α, β) = (20,40,800)	
	type one ($\mathbf{x}_1, \mathbf{x}_2, \mathbf{x}_3$) = (0, α , 0) type two ($\mathbf{x}_1, \mathbf{x}_2, \mathbf{x}_3$) = (0, 0, β) type three ($\mathbf{x}_1, \mathbf{x}_2, \mathbf{x}_3$) = (γ , 0, 0)	type one ($\mathbf{x}_1, \mathbf{x}_2, \mathbf{x}_3$) = (0, 0, β) type two ($\mathbf{x}_1, \mathbf{x}_2, \mathbf{x}_3$) = (γ , 0, 0) type three ($\mathbf{x}_1, \mathbf{x}_2, \mathbf{x}_3$) = (0, α , 0)
q>1 q = 3 for experiments	unstable counter clockwise equilibrium prices (40,20)	stable equilibrium prices (40,20)
q=1	limit cycle counter clockwise equilibrium prices (40,20)	limit cycle clockwise equilibrium prices (40,20)
q<1 q = 1/3 for experiments	stable equilibrium prices (40,20)	unstable clockwise equilibrium prices (40,20)

Table A2 contains the parameter set for the experiments conducted. The information in this table is essentially the same as the information in Table 1 in the text. It is included here for the convenience of readers who want to compare the parameters that were implemented to the more general possibilities.

Table A2: Preferences And Endowments				
	Type i = 1,2,3	$U^i(x_i, y_i, z_i)$	endowments $\omega_i = (x_i, y_i, z_i)$	Remarks
Clockwise: $q=1/3$, (γ, α, β) = (20,40,800); Equilibrium $P_x = \beta/\gamma$, $P_y = \beta/\alpha$				
	1	$\min\{3y/40, z/800\}$	$\omega_1=(0,0,800)$	The classical model predicts divergence with tendencies in a clockwise direction.
	2	$\min\{x/20, 3z/800\}$	$\omega_2=(20,0,0)$	
	3	$\min\{3x/20, y/40\}$	$\omega_3=(0,40,0)$	
Counter Clockwise: $q = 3$, (γ, α, β) = (20,40,800)				
	1	$\min\{y/120, z/800\}$	$\omega_1=(0,40,0)$	The classical model predicts divergence with tendencies in a counter clockwise direction.
	2	$\min\{x/20, z/2400\}$	$\omega_2=(0,0,800)$	
	3	$\min\{x/60, y/40\}$	$\omega_3=(20,0,0)$	

APPENDIX B: Sensitivity of Price Changes to Price Levels

To explore the possibility that the rates of price adjustment are sensitive to the level of prices, we examined several possibilities. First, we examined whether price changes vary linearly in price. Linear regressions were performed and the results are presented in Tables B1 and B2.

Table B1: $\dot{P}_X = a_{session} + a_{XX}E_X(P_X, P_Y) + a_{XY}E_Y(P_X, P_Y) + b_{XX}P_X + b_{XY}P_Y$

	Estimate	Std. Error	t value	Pr(> t)
(Intercept)	-2.19163	1.642725	-1.334	0.18482
$E_X(P)$	0.681776	0.264441	2.578	0.01121
$E_Y(P)$	0.026619	0.112791	0.236	0.81385
P_X	0.028415	0.009914	2.866	0.00495
P_Y	-0.003253	0.008774	-0.371	0.71152
021211	2.011362	1.998584	1.006	0.31636
030130	-0.205054	2.358881	-0.087	0.93088
030428	-2.606954	3.568085	-0.731	0.4665
030620	-2.20595	2.754135	-0.801	0.42482
030717	1.985534	1.968964	1.008	0.31539

Residual standard error: 5.683 on 114 degrees of freedom
 Multiple R-Squared: 0.2155, Adjusted R-squared: 0.1536
 F-statistic: 3.48 on 9 and 114 DF, p-value: 0.0007877

Table B2: $\dot{P}_Y = a_{session} + a_{YX}E_X(P_X, P_Y) + a_{YY}E_Y(P_X, P_Y) + b_{YX}P_X + b_{YY}P_Y$

	Estimate	Std. Error	t value	Pr(> t)
(Intercept)	0.92964	1.136122	0.818	0.414918
$E_X(P)$	-0.584541	0.182889	-3.196	0.001802
$E_Y(P)$	0.113297	0.078007	1.452	0.149138
P_X	-0.005932	0.006857	-0.865	0.388746
P_Y	0.022292	0.006068	3.674	0.000366
021211	-1.902095	1.382237	-1.376	0.171488
030130	-0.684075	1.631421	-0.419	0.675777
030428	5.214188	2.467717	2.113	0.036786
030620	0.147808	1.904783	0.078	0.938284
030717	-2.096539	1.361751	-1.54	0.126432

Residual standard error: 3.93 on 114 degrees of freedom
 Multiple R-Squared: 0.3402, Adjusted R-squared: 0.2882
 F-statistic: 6.532 on 9 and 114 DF, p-value: 1.805e-07

Notice that the price of X has a significant coefficient in the X market and that the price of Y has a significant coefficient in the Y market. Such sensitivities suggested to us that prices need to be included in the model somehow. For example, the A matrix might be of the form A(P). Further analysis indicated that the dependence on P does not appear linear, and instead there is an interaction between excess demand and price. A shingle-plot of relationship of price change and excess demand shows this relationship (Figure B1 and B2).

Each panel of the shingle plot shows scatter plot of price change against excess demand at a particular range of price. The prices are increasing from left to right, and bottom to top, in the panels. This plot clearly shows that the relationship of price change with excess demand changes across the range of prices. In particular, prices changes appear to respond greater to excess demand at higher price levels.

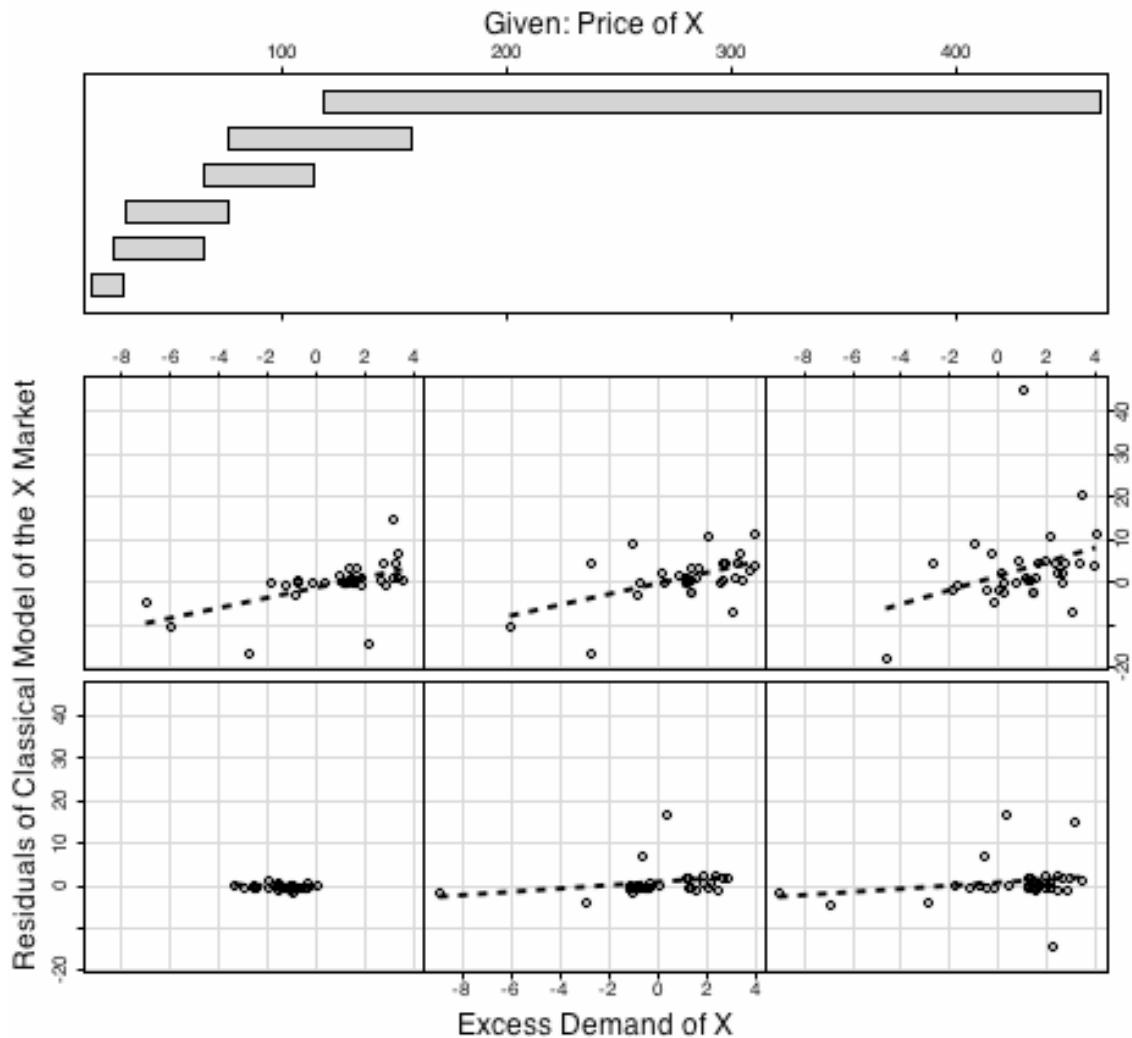

Figure B1: Shingle plot of price changes on excess demand in market X, conditional on intervals of X prices. Notice the clear interaction between slope of excess demand and with price levels.

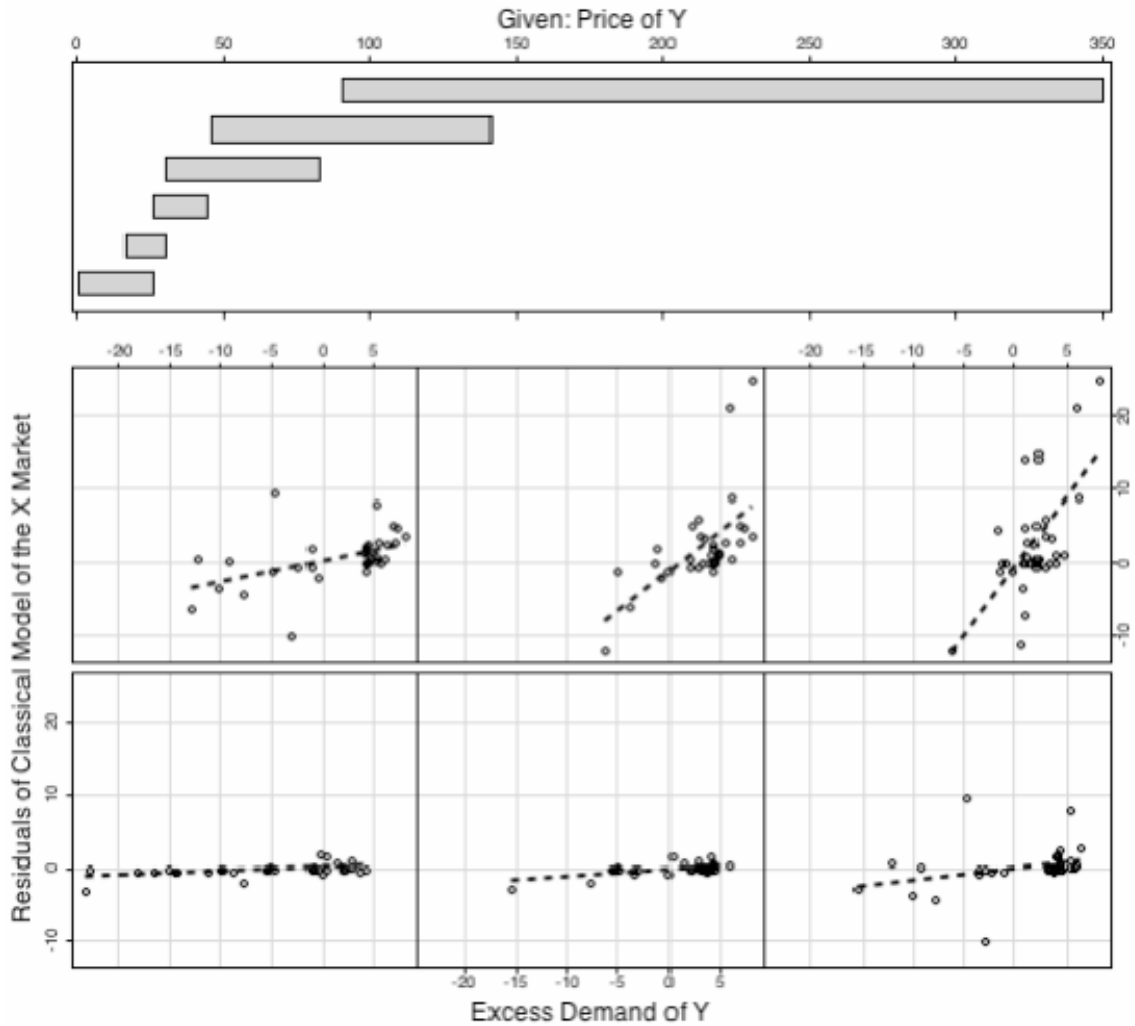

Figure B2: Shingle plot of price changes on excess demand in market Y, conditional on intervals of Y prices. Notice the clear interaction between slope of excess demand and with price levels.

APPENDIX C:

The Newton Model

Recall the Newton model fit poorly to the data. Here we provide intuition behind this result. In particular, the equilibrium is locally stable under the Newton method. More generally, the Scarf environment is stable under the Newton method in the price space typically traversed in these experiments. Figure C1 shows simulations of the Newton model under various starting points.

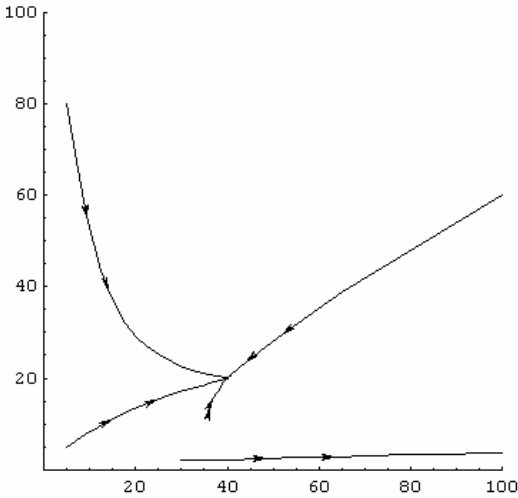

Figure C1: Simulation of price dynamics under Newton model with starting points (5, 80), (5,5), (100, 60), (36, 12), (30,2).

We explore why the Newton models fit the data so poorly. The basic reason is that the Newton Models predict convergence when the data demonstrate divergence.

The differential equation of the Newton model is defined as

$$\begin{pmatrix} \dot{P}_X \\ \dot{P}_Y \end{pmatrix} = -J^{-1}(P) \begin{pmatrix} E_X(P) \\ E_Y(P) \end{pmatrix}$$

In the above $J(P) = \begin{pmatrix} J_{11} & J_{12} \\ J_{21} & J_{22} \end{pmatrix} = \begin{pmatrix} \frac{\partial E_X(P)}{\partial P_X} & \frac{\partial E_X(P)}{\partial P_Y} \\ \frac{\partial E_Y(P)}{\partial P_X} & \frac{\partial E_Y(P)}{\partial P_Y} \end{pmatrix}$ is the Jacobian of the excess

demand functions.

For the clockwise condition, the Jacobian matrix is:

$$\left(\begin{array}{cc} -\frac{20P_x}{\left(\frac{40}{3} + P_x\right)^2} + \frac{60}{40 + 3P_x} - \frac{40P_y}{(P_x + 6P_y)^2} & \frac{40P_x}{(P_x + 6P_y)^2} \\ -\frac{240P_y}{(P_x + 6P_y)^2} & \frac{80(-10P_x^2 - 360P_y^2 + 3P_x(3600 + 80P_y + P_y^2))}{(60 + P_y)^2(P_x + 6P_y)^2} \end{array} \right)$$

Evaluating $|J(P)| = 0$ separates the price space into stable and unstable portions as shown in Figure C2.

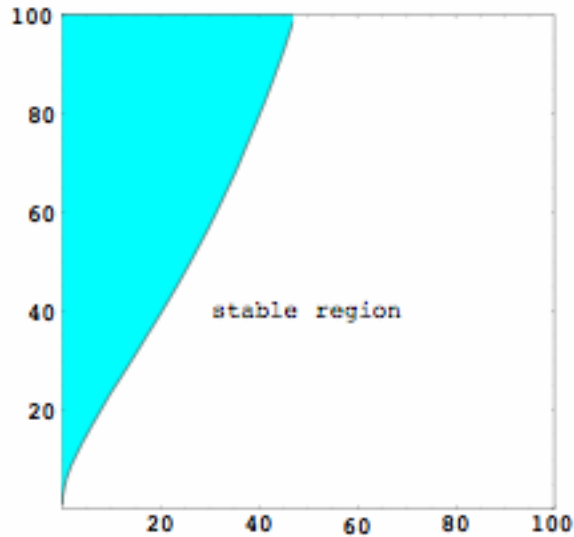

Figure C2

For any initial position for stable portion, the Newton differential equations system converges to the equilibrium price.

For the Counterclockwise condition, the Jacobian matrix is:

$$\left(\begin{array}{cc} 20 \left(-\frac{40}{(120 + P_x)^2} - \frac{9P_x}{(3P_x + 2P_y)^2} + \frac{3}{3P_x + 2P_y} \right) & -\frac{120P_x}{(3P_x + 2P_y)^2} \\ \frac{80P_y}{(3P_x + 2P_y)^2} & 40 \left(-\frac{2P_x}{(3P_x + 2P_y)^2} + \frac{60}{(20 + 3P_y)^2} \right) \end{array} \right)$$

Evaluating $|J(P)| = 0$, the stable and unstable portions are shown in Figure C3.

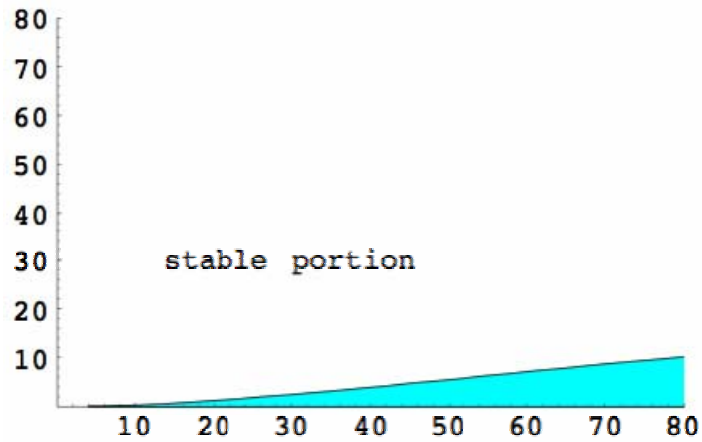

Figure C3

Recall that initial prices for all but the first experiment were near $(25,25)$, which is in the stable portion for both conditions. This fact explains why the Newton model fit so poorly. The Newton model predicts that movement should be toward the interior equilibrium but the data diverge. Thus, the dynamics of the data and price movements cannot be represented by the Newton model of price adjustment.

APPENDIX D: Individual session estimates

Classical model

Table D1: X equation

Condition	Session	Parameter	Estimate	Std. Error	t value	Pr(> t)	R ²	F-stat
Clockwise	021127	(Intercept)	-2.847	2.768	-1.028	0.319	0.380	4.894
		EMX	1.599	1.194	1.339	0.199		
		EMY	-0.241	0.264	-0.914	0.374		
Clockwise	021211	(Intercept)	1.260	0.960	1.312	0.199	0.110	1.968
		EMX	0.960	0.530	1.812	0.079		
		EMY	-0.010	0.165	-0.060	0.953		
Clockwise	030717	(Intercept)	1.511	0.713	2.120	0.042	0.186	3.545
		EMX	0.612	0.392	1.559	0.129		
		EMY	-0.087	0.189	-0.463	0.646		
Counterclockwise	030130	(Intercept)	0.204	0.956	0.214	0.834	0.362	3.980
		EMX	0.613	0.232	2.647	0.019		
		EMY	0.071	0.292	0.244	0.810		
Counterclockwise	030428	(Intercept)	3.685	4.901	0.752	0.474	0.200	0.998
		EMX	2.494	3.543	0.704	0.501		
		EMY	-0.309	1.006	-0.307	0.767		
Counterclockwise	030620	(Intercept)	-4.740	3.560	-1.332	0.240	0.384	1.560
		EMX	3.864	2.268	1.704	0.149		
		EMY	0.898	0.840	1.069	0.334		

Table D2: Y equation

Condition	Session	Parameter	Estimate	Std. Error	t value	Pr(> t)	R ²	F-stat
Clockwise	021127	(Intercept)	1.478	1.163	1.271	0.222	0.134	1.236
		EMX	-0.788	0.502	-1.572	0.136		
		EMY	0.173	0.111	1.562	0.138		
Clockwise	021211	(Intercept)	0.846	0.967	0.875	0.388	0.113	2.041
		EMX	-0.368	0.533	-0.690	0.495		
		EMY	0.248	0.166	1.495	0.145		
Clockwise	030717	(Intercept)	0.119	0.424	0.281	0.781	0.216	4.270
		EMX	-0.247	0.233	-1.061	0.297		
		EMY	0.136	0.112	1.215	0.233		
Counterclockwise	030130	(Intercept)	0.212	0.709	0.300	0.769	0.407	4.802
		EMX	-0.217	0.172	-1.261	0.228		
		EMY	0.438	0.216	2.024	0.062		
Counterclockwise	030428	(Intercept)	6.247	2.394	2.610	0.031	0.539	4.680
		EMX	-4.050	1.730	-2.340	0.047		
		EMY	-0.195	0.491	-0.397	0.702		
Counterclockwise	030620	(Intercept)	1.396	0.393	3.551	0.016	0.650	4.644
		EMX	-0.669	0.250	-2.670	0.044		
		EMY	-0.114	0.093	-1.227	0.274		

Price-Scaled model

Table D3: X equation

Condition	Session	Parameter	Estimate	Std. Error	t value	Pr(> t)	R ²	F-stat
Clockwise	021127	(Intercept)	-2.060	1.432	-1.439	0.170	0.374	4.781
		Px:EMX	0.017	0.008	2.024	0.060		
		Px:EMY	-0.002	0.002	-1.219	0.241		
Clockwise	021211	(Intercept)	-0.055	1.128	-0.049	0.961	0.391	10.270
		Px:EMX	0.017	0.004	4.531	0.000		
		Px:EMY	0.001	0.000	1.267	0.214		
Clockwise	030717	(Intercept)	0.926	1.128	0.821	0.418	0.100	1.717
		Px:EMX	0.008	0.005	1.575	0.125		
		Px:EMY	0.000	0.001	0.336	0.739		
Counterclockwise	030130	(Intercept)	-0.454	1.038	-0.438	0.668	0.356	3.864
		Px:EMX	0.008	0.003	2.778	0.015		
		Px:EMY	0.002	0.002	1.093	0.293		
Counterclockwise	030428	(Intercept)	6.343	5.007	1.267	0.241	0.395	2.607
		Px:EMX	0.013	0.017	0.769	0.464		
		Px:EMY	-0.003	0.003	-0.913	0.388		
Counterclockwise	030620	(Intercept)	-4.691	4.325	-1.085	0.328	0.285	0.998
		Px:EMX	0.028	0.020	1.413	0.217		
		Px:EMY	0.008	0.009	0.952	0.385		

Table D4: Y equation

Condition	Session	Parameter	Estimate	Std. Error	t value	Pr(> t)	R ²	F-stat
Clockwise	021127	(Intercept)	0.104	0.387	0.269	0.791	0.088	0.772
		Py:EMX	0.000	0.004	-0.071	0.944		
		Py:EMY	0.005	0.004	1.237	0.234		
Clockwise	021211	(Intercept)	-0.334	0.972	-0.344	0.733	0.338	8.160
		Py:EMX	-0.001	0.003	-0.512	0.612		
		Py:EMY	0.012	0.003	3.944	0.000		
Clockwise	030717	(Intercept)	-0.052	0.453	-0.115	0.909	0.257	5.352
		Py:EMX	-0.002	0.002	-1.036	0.308		
		Py:EMY	0.004	0.002	2.446	0.020		
Counterclockwise	030130	(Intercept)	0.106	0.650	0.163	0.873	0.433	5.356
		Py:EMX	0.001	0.002	0.300	0.769		
		Py:EMY	0.008	0.003	2.693	0.017		
Counterclockwise	030428	(Intercept)	0.675	2.500	0.270	0.794	0.650	7.419
		Py:EMX	-0.016	0.014	-1.099	0.304		
		Py:EMY	0.015	0.008	1.849	0.102		
Counterclockwise	030620	(Intercept)	0.845	0.390	2.166	0.083	0.676	5.223
		Py:EMX	-0.016	0.007	-2.225	0.077		
		Py:EMY	-0.003	0.004	-0.811	0.454		

Mixed Effects Models

As was stated in the paper, mixed effects models were also estimated for the various models. Mixed effects models allow us to better capture the panel-nature of the experimental data. In particular, by using mixed effects models, we are able to relax the assumption of a common adjustment matrix for all sessions, which we imposed in the OLS regressions presented in the paper.

The random-effects model treats the variation of the adjustment matrix between sessions as random variation around a population mean.

Denote each session by s , where $s \in (1, 2, \dots, S)$, $S = 6$; and trade t in each session $t \in (1, 2, \dots, T_s)$.

We define

$$\dot{P}_{s,t} = \alpha_0 + P_{s,t} E(P_{s,t}) \mathbf{a} + a_s + \varepsilon_{s,t}, t = 1, \dots, T_s, s = 1, \dots, S.$$

$$a_s \sim N(0, \Psi_s), \varepsilon_{s,t} \sim N(0, \sigma^2 I)$$

Intuitively, we separate the effects into two levels. The coefficient \mathbf{a} represents the true effect of price scaled excess demand on prices changes. The random variable a_s is the variance around \mathbf{a} between the sessions. This model and variations of the model were estimated using the nlme package in R (Pinheiro and Bates, 2000).

Here we report the estimates for the X equation of the price scaled model. The estimates of the fixed effects \mathbf{a} are

	Value	Std.Error	t-value	p-value
(Intercept)	0.4331188	0.5237794	0.826911	0.41
$P_X E_X(P)$	0.0129623	0.0028452	4.555891	0
$P_X E_Y(P)$	0.0002188	0.0006488	0.337245	0.7365

Compared to the estimates in OLS in Table 8A, where the coefficient on $P_X E_X(P) = 0.0148$ (s.e. = 0.00286), $P_X E_Y(P) = -0.000533$ (s.e. = 0.000557), the estimates in the mixed effects model are very similar.

The standard deviation given by the random effects variance-covariance matrix, Ψ_s , is 0.00317 for $P_X E_X(P)$, and 0.000731 for $P_X E_Y(P)$. Note that the standard deviation of the significant term $P_X E_X(P)$ is less than 1/4 of the estimated coefficient. This supports the choice of a fixed effects model, as appears to be little variation around the mean between sessions.

For completeness, we reproduce the mixed effects estimates for the Y equation of the price scaled model.

	Value	Std.Error	t-value	p-value
(Intercept)	0.014664218	0.3608543	0.040637	0.9677
$P_Y E_X(P)$	-0.001883857	0.0015816	-1.191144	0.236
$P_Y E_Y(P)$	0.00926924	0.0029225	3.171642	0.0019

As is clear, these estimates are very close to these presented in the OLS model in Table 8B.

REFERENCES

- Anderson, Christopher M., C. R. Plott, and K. I. Shimomura, and S. Granat, "Global Instability in Experimental General Equilibrium: The Scarf Example." *Journal of Economic Theory*, 115(2), (April 2004):209-249.
- Asparouhova, Elena, Peter Bossaerts, and Charles Plott, "Excess Demand and Equilibration in Multi-security Financial Markets: The Empirical Evidence," *Journal of Financial Markets* 6, (2003):1-21.
- Bossaerts, Peter L., C. R. Plott, and W. Zame, "The Role of Excess Demand in Determining Marginal Price Changes in the Equilibration of Competitor Markets." California Institute of Technology, Pasadena, California (2001).
- Carlson, John A., "The Stability of an Experimental Market with a Supply-Response Lag", *Southern Economic Journal*, 33(3) (January 1967):305-321.
- Steven Gjerstad, "Market Dynamics in Edgeworth Exchange" University of Arizona, January 19, 2004.
- Hirota, Masayoshi, "On the Stability of Competitive Equilibrium and the Patterns of Initial Holdings: An Example." *International Economic Review* 22, (1981):461-7.
- Hirota, Masayoshi, "Global Stability in a Class of Markets with Three Commodities and Three Consumers", *Journal of Economic Theory* 36(1), (June 1985):186-192.
- Hirota, Masayoshi, "On the Probability of the Competitive Equilibrium Being Globally Stable: The C.E.S. Example", California Institute of Technology, Pasadena, California 1129R, April 2004.
- Johnson, Michael D. and C. R. Plott, "The Effect of Two Trading Institutions on Price Expectations and the Stability of Supply-Response Lag Markets." *Journal of Economic Psychology* 10, (1989):189-216.
- Lian, Peng and C. R. Plott, "General Equilibrium, Markets, Macroeconomics and Money in a Laboratory Experimental Environment." *Economic Theory* 12(1), (1998):21-75.
- Noussair, Charles N., R. G. Riezman, and C. R. Plott, "An Experimental Investigation of the Patterns of International Trade," *American Economic Review* 85(3), (June 1995):462-91.
- Noussair, Charles, Charles R. Plott and Ray Riezman, "The Principles of Exchange Rate Determination in an International Finance Experiment," *Journal of Political Economy* 105(4), (August 1997):822-61.

- McKenzie, Lionel W., *Classical General Equilibrium Theory*, MIT Press, Cambridge, Mass. 2002.
- Mukherji, Anjan, *An Introduction to General Equilibrium Analysis*, Oxford University Press, India, 2002.
- Mukherji, Anjan, "A Locally Stable Adjustment Process," *Econometrica* 63(2), (March, 1995):441-448.
- Mukherji, Anjan, *Competitive Equilibria: Convergence, Cycles or Chaos*, Centre for Economic Studies and Planning, Jawaharlal Nehru University, New Delhi, PRELIMINARY (2003).
- Mukherji, Anjan, "A Global Stability Condition: Generalized Law of Demand", presented at: International Conference on Economic Theory, Tokyo, March 2004, organized by Keio University and Kyoto University.
- Plott, Charles R., "Equilibrium, Equilibration, Information and Multiple Markets: From Basic Science to Institutional Design," Nobel Symposium Behavioral and Experimental Economics, December 2001.
- Plott, Charles R., "Market Stability: Backward Bending Supply in a Laboratory Market." *Economic Inquiry* 38(1), (2000):1-18.
- Plott, Charles R., and G. George, "Marshallian vs. Walrasian Stability in an Experimental Market.: *Economic Journal* (May 1992):437-60.
- Plott, Charles R., and P. Gray, "The Multiple Unit Double Auction." *Journal of Economic Behavior and Organization* 13, (1990):245-58.
- Plott, Charles R., and J. Smith, "Instability of Equilibria in Experimental Markets: Upward-Sloping Demands, Externalities, and Fad-Like Incentives." *Southern Economic Journal* 65(3), (January 1999):405-426.
- Saari, Donald, "Iterative Price Mechanisms" *Econometrica* 53, (1985):1117-1132.
- Saari, Donald and C.T. Simon, "Effective Price Mechanisms", *Econometrica* 46, (1978):1097-1125.
- Saari, Donald G, and Steve Williams, "On the Local Convergence of Economic Mechanisms", *Journal of Economic Theory* 49(1), (October, 1986):152-167.
- Scarf, Herbert, "Some Examples of Global Instability of the Competitive Equilibrium." *International Economic Review* 1, (1960):157-71.

Smale, S., "A Convergent Process of Price Adjustment and Global Newton Methods,"
Journal of Mathematical Economics 3, (1976):107-120.

Smith, Vernon L., "Experimental Auction Markets and the Walrasian Hypothesis"
Journal of Political Economy, (August 1965).

Williams, Arlington, V. L. Smith, J. O. Ledyard, and S. Gjerstad, "Concurrent Trading in
Two Experimental Markets with Demand Interdependence," *Economic Theory*
16, (November 2000):511-528.